

OREGON JOINT USE ASSOCIATION STANDARDS COMMITTEE

BEST PRACTICES GUIDE



APRIL 2009



ACKNOWLEDGMENTS

Construction Standards Subcommittee

Membership

Dave Cheney, Accent Communications

Stan Cowles, Qwest

Jim Flu, PacifiCorp

Keshvar Jafari, PGE

Scott Jennings, Verizon

Tamara Johnson, Springfield Utility Board

Rob Kolosvary, PGE

Gary Lee, Charter Communications

Jeff Liberty, Bend Broadband

Jim McGuire, PGE

Michelle Ness, Central Lincoln PUD

Gary Payne, Qwest

Gary Putnam, PUC

Troy Rabe, Comcast

Stuart Sloan, Consumers Power

John Wallace, PUC

Jim Watkins, PacifiCorp

Scott Wheeler, Comcast

Bill Woods, PacifiCorp

TABLE OF CONTENTS

Chapter 1 - Anchors	1
A. Placement Considerations:	1
B. Common Types of Anchors and Installation	4
Testing the Anchor:	8
Chapter 2 - Bonding and Grounding	9
A. Definition of Bonding	9
B. Bonding Installation Considerations	10
C. Types of Bonds Installations:	10
D. Types of Bonding Connectors:	11
E. Definition of Grounded	11
F. Grounding Installation Considerations	11
G. Types of Grounds	12
H. Street Light Grounding	13
I. Bonding Risers	14
Chapter 3 - Framing	15
A. Definition of Framing	15
B. Site Specific Construction	15
C. Types of Framing	16
D. Avian Protection Construction	20
E. Construction Practices	20
F. Ground Clearances	20
G. Voltage Clearances	21
Chapter 4 - Poles	22
A. Definition of a Pole	22
B. Placement	22
C. Types	22
D. Identification	23
E. Grades of Construction	24
F. Pole Class:	24
G. Pole top Extensions	25
H: Pole Supports:	26
Chapter 5 - Risers	29
A. Definition of Riser	29
B. Placement Considerations:	29
Chapter 6 - Tension and Sag	34
A1. Definition of Tension	34
A2. Definition of Sag	34
B. Engineering Design	35
C. Methods of Tensioning:	35
D. SLACK SPAN (Reduced Tension Construction)	36
E. Guy Tension	36
F. Line of Sight	37
G. Sag Charts	37
H. Loading Zone:	38
I. Grades of Construction	39
J. Resources:	40

Chapter 7 - Support Arms	41
A. Definition of Support Arm	41
B. Placement considerations	41
C. Types:	42
D. Braces:	48
E. Lengths of Arms:	48
F. Pole Gains	49
G. Installation:	49
Chapter 8 - Equipment Pictorial	50
A. Definition of Equipment	50
B. General Equipment	50
C. Supply Equipment	52
D. Telco Equipment:	54
E. Cable Equipment:	55
F. Fiber Equipment	55
G. Wireless Equipment	56

CHAPTER 1 - ANCHORS

This document is intended to provide education on common Construction Practices for aerial construction of power and telecommunications facilities. This is not an official codebook, nor should it be construed as a construction manual. When constructing aerial facilities, please refer to the governing codes, such as the National Electrical Safety Code, National Electric Code, Oregon Public Utility Commission Safety Rules, Oregon Occupational Safety And Health Administration, State, County and Municipal codes, and all other applicable standards, including contracts.

The 2007 National Electrical Safety Code (NESC) addresses anchors in Sections 253, 261, and 264

Table of Contents:

A. Placement Considerations

B. Common Types of Anchors & Installation

A. PLACEMENT CONSIDERATIONS:

The distance between the anchor and the pole is generally based on the load the anchor is required to hold, and the anchor type. There are other considerations that are dealt with in this chapter as well.

Anchors are generally placed five (5) feet from an existing anchor. This is done to ensure the soil surrounding the existing anchor is not loosened while installing the new anchor.

Heights to lead ratio means that for every one foot of pole height that place your attachment, you place the anchor one foot away from the pole.

- 1:1 ratio is optimum
- 2:1 ratio is good
- 3:1 ratio is the minimum

When identifying the need to have your plant guyed at a specific location, you may observe another utilities' anchor. This anchor may have an available open eye. You must first get permission from the anchor owner prior to occupying that open eye with your guy.

These are “eye” bolts that are attached to an anchor rod above grade.

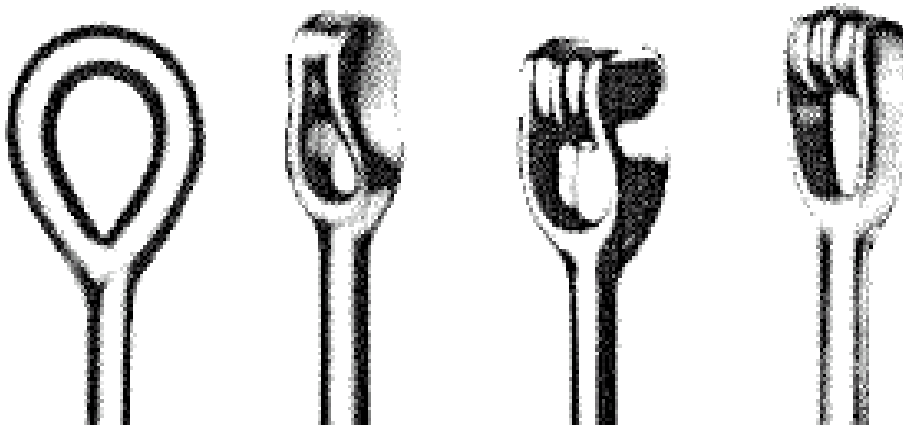

When all available eyes on the rod are occupied, some utilities may allow the use of auxiliary eye attachments. This hardware is clamped to the existing rod above grade, and enables another guy to be attached to the anchor.

Newly installed anchor rods should have no more than 12” of exposed rod above grade.

Anchor rods should be placed in lead with the facilities they are supporting. The rod should be aimed towards the spot on the pole where the guy is attached (with the exception of sidewalk guys).

Soil Types: Soil testing is necessary to determine the proper anchor type. A soil probe is performed with a mechanical soil test probe tool that is screwed into the soil. As it displaces the soil, probe installation torque is measured in inch-pounds on a torque gauge, which is an integral part of the installing tool. Probe torque readings are then compared with the information on the Soil Classification Data Chart and translated into the appropriate soil classification.

SOIL CLASSIFICATION DATA

Class	Common Soil-Type Description	Geological Soil Classification	Probe Values in.-lb. (N.M)	Typical Blow Count "N" per ASTM-D1586
0	Sound hard rock, unweathered	Granite, Basalt, Massive Limestone	N.A.	N.A.
1	Very dense and/or cemented sands; coarse gravel and cobbles	Caliche, (Nitrate-bearing gravel/rock).	750 - 1600 (85 - 181)	60-100+
2	Dense fine sands; very hard silts and clays (may be preloaded)	Basal till; boulder clay; caliche; weathered laminated rock	600-750 (68 - 85)	45-60
3	Dense sands and gravel; hard silts and clays	Glacial till; weathered shales, schist, gneiss and siltstone	500 - 600 56 - 68	35-50
4	Medium dense sand and gravel; very stiff to hard silts and clays	Glacial till; hardpan; marls	400 - 500 (45 - 56)	24-40
5	Medium dense coarse sands and sandy gravels; stiff to very stiff silts and clays	Saprolites, residual soils	300 - 400 (34 - 45)	14-25
6	Loose to medium dense fine to coarse sands to stiff clays and silts	Dense hydraulic fill; compacted fill; residual soils	200 - 300 (23 - 34)	7-14
**7	Loose fine sands; Alluvium; loess; medium - stiff and varied clays; fill	Flood plain soils; lake clays; adobe; gumbo, fill	100 - 200 (11 - 23)	4-8
**8	Peat, organic silts; inundated silts, fly ash very loose sands, very soft to soft clays	Miscellaneous fill, swamp marsh	less than 100 (0 - 11)	0-5

Class 1 soils are difficult to probe consistently and the ASTM blow count may be of questionable value.

**It is advisable to install anchors deep enough, by the use of extensions, to penetrate a Class 5 or 6, underlying the Class 7 or 8 Soils.

Easement Considerations: An **easement** is the right of use over the real property of another. It is distinguished from a license or permit that only gives one a personal privilege to do something on the land of another usually the permission to pass over the property without creating a trespass. Easements may be considered public or private. A private easement is limited to a specific individual such as the owner of an adjoining land. A public easement is one that grants the right to a large group of individuals or to the public in general, such as the easement on public streets and highways. You must consider land use easements when placing an anchor!

Permit Considerations: There are many different permits that may be required that are related to construction activity of this type, including Oregon Department of Transportation, City, Municipal, and others. Please consult the necessary agencies to ensure you are in compliance with the governing agencies.

Locates: The Oregon Utility Notification Center (OUNC) is the one-call agency dedicated to safeguarding citizens and construction personnel who work around utilities, as well as safeguarding the underground infrastructure of pipes, mains and lines which bring utilities to your community. Calling at least two working days before beginning any excavation prevents damage to underground facilities, service interruptions, and bodily injury. The number is **1-800-332-2344**.

B. COMMON TYPES OF ANCHORS AND INSTALLATION

- Plate
- Helix / Screw
- Expanding / Bust
- Manta Ray
- Swamp
- Rock

Plate anchor:

The Cross-Plate anchor is made for installation in holes drilled by power diggers. Because the size of the hole does not affect holding capacity, the same auger that is used to dig the pole holes on transmission projects can dig the hole. Cross-Plate anchors are installed in a diagonal bored hole, which is undercut so the anchor is at right angles to the guy. A rod trench is either cut with a trenching tool or drilled with a small power auger. Both anchor and rod trench should be refilled and tamped.

The Cross-Plate anchor is made for installation in holes drilled by power diggers. Because the size of the hole does not affect holding capacity, the hole can be dug by the same auger that is used to dig the pole holes on transmission projects.

Cross-Plate anchors are installed in a diagonal bored hole which is undercut so the anchor is at right angles to the guy. A rod trench is either cut with a trenching tool or drilled with a small power auger. Both anchor and rod trench should be refilled and tamped.

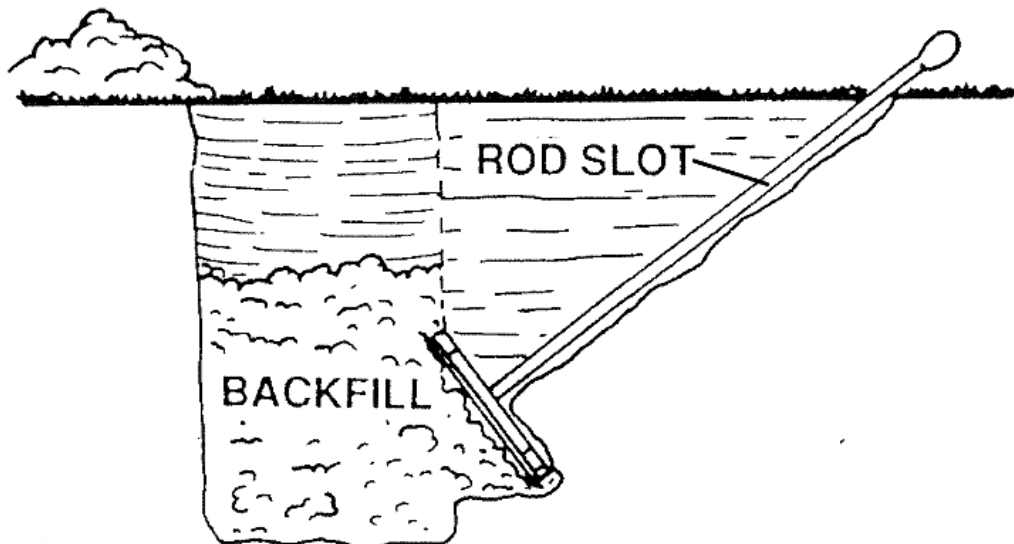
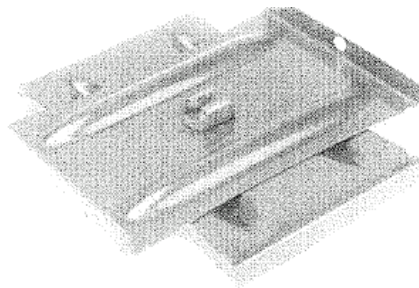

Helix / Screw anchor:

Screw-in anchors are recommended for softer soil types, Classes 5-7 in Table 1. They do not work well in rocky soils. Screw-in anchors are usually installed by two people rotating a log bar threaded through the eye, but may also be installed with a power drive machine. Screw-in anchors can also be used in applications where an anchor will be embedded in concrete.

Single Helix Anchor

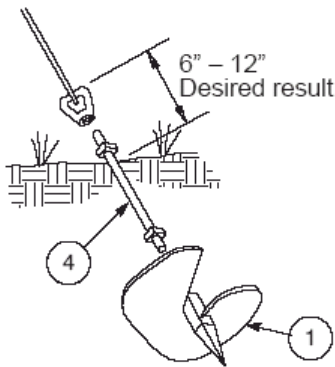

Twin-Helix Anchor

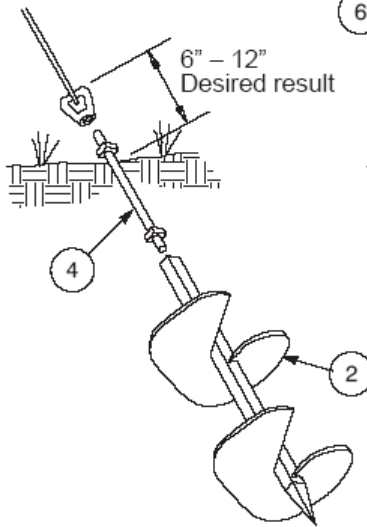

Triple Helix Anchor

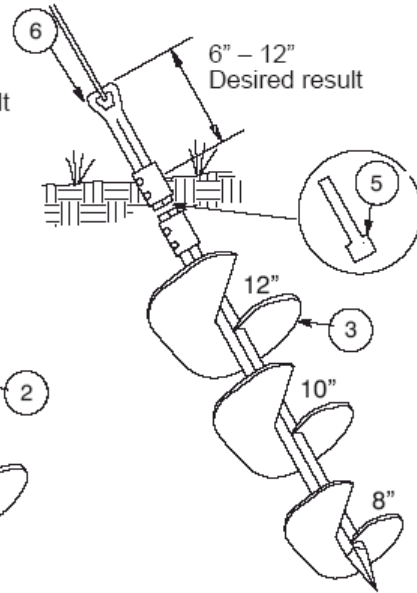

Expanding / Bust anchor:

“Bust” Expanding Anchors expand to take full advantage of the available area. All eight blades wedge into undisturbed earth. There is no wasted space between blades. This anchor should be installed in relatively dry and solid soils. The effectiveness of the anchor is dependent upon the thoroughness of backfill tamping.

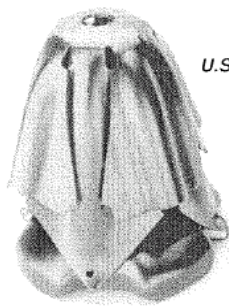

U.S. Patent No. 5,775,848

MORE HOLDING CAPACITY FOR LESS

Four different sizes are available with holding capacity as high as 40,000 pounds.

Chance “Bust” Expanding Anchors expand to take full advantage of the available area. All eight blades wedge into undisturbed earth . . . there is no wasted space between blades.

This anchor should be installed in relatively dry and solid soils. The effectiveness of the anchor is dependent upon the thoroughness of backfill tamping.

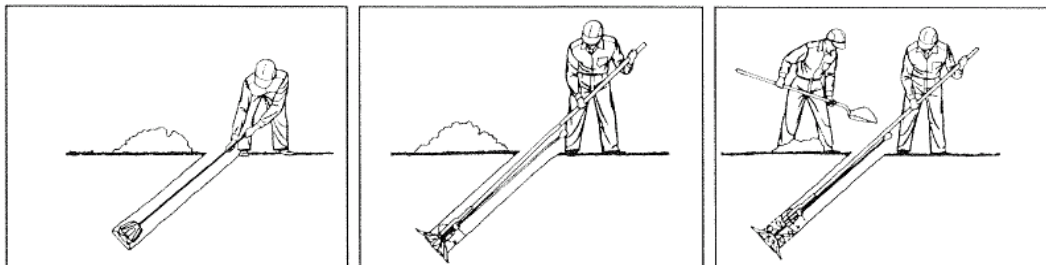

Manta Ray anchor:

MANTA RAY's are driven into the ground, not augured or torqued, nor is a hole dug or drilled. There is "no disturbance" or "displacement" of soil. Unlike other anchoring systems, MANTA RAY actually compacts the soil around itself - a clean, safe and simple operation.

The anchors are driven with conventional hydraulic/pneumatic equipment that is readily available worldwide. Once driven to the proper depth, the rod/tendon attached to the anchor is pulled to rotate the anchor into undisturbed soil - like a toggle bolt. This is called "ANCHOR LOCKING" the anchor (using the MANTA RAY Anchor Locker). The anchor is pulled upon to reach the holding capacity required which is measured by a gauge on the "ANCHOR LOCKER." Each anchor is immediately proof loaded to the exact capacity required.

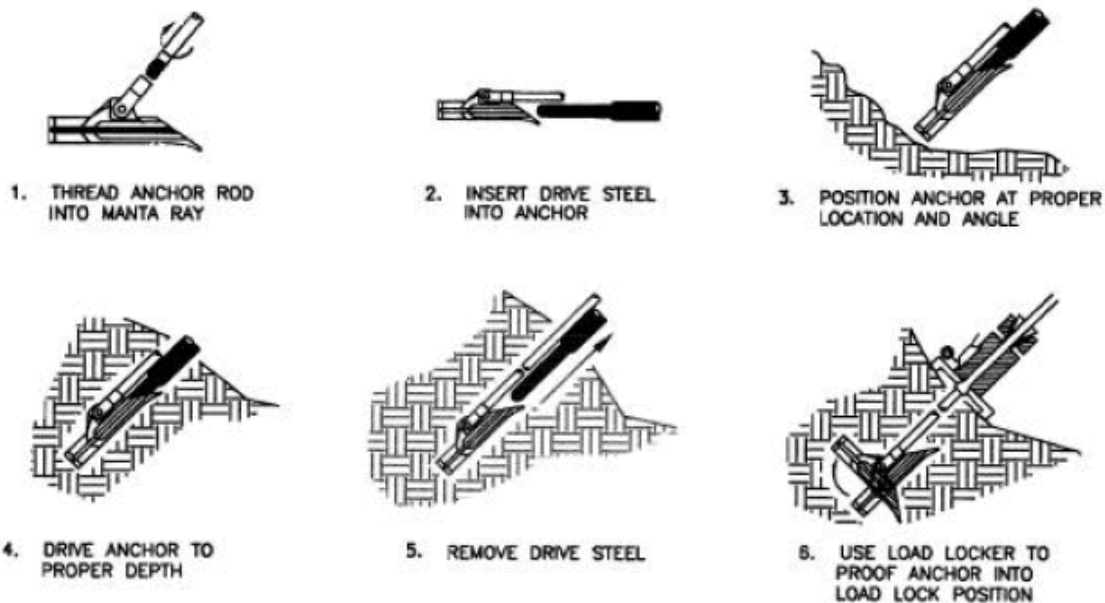

Swamp anchor: No picture or installation available

Swamp anchors can also be buried logs that brace a wood pole and are used in marshy and swampy terrain (also called swamp brace or brace anchor).

Rock anchor:

Rock anchors are standard in the construction industry for rocky areas. They are appropriate for soil Classes 0-1 in Table 1. They require drilling a hole for insertion of a threaded rock anchor. The anchor can then be cemented into place if desired. Grouting is necessary with soft, crumbling rocks or if weathering is expected. The hole is bored with a hand or power drill, larger than the diameter of the unexpanded anchor. The anchor is then dropped into the hole, and the eye is threaded with a bar and rotated until the anchor has expanded firmly against the sides of the hole. The anchor must be aligned with the guy loads, and should be installed at least 12" (305mm) into solid rock. The anchor wedges and expands against walls of solid rock. Once it is set, the more pull on the rod, the tighter it wedges.

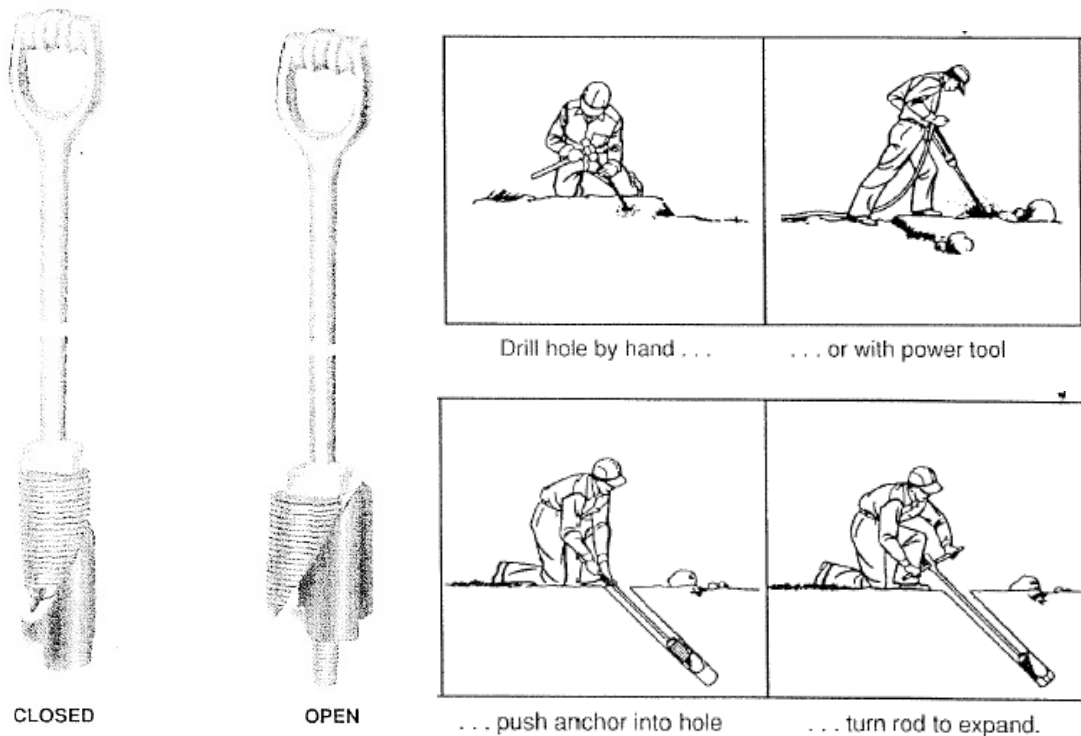

TESTING THE ANCHOR:

A dynamometer is used to test the holding capacity of an anchor (or messenger strand as illustrated below). One end is attached to the anchor eye, and the other to a chain hoist that is temporarily attached to the pole. Tension is placed on the dynamometer by ratcheting the chain hoist till the desired holding capacity is observed.



CHAPTER 2 - BONDING AND GROUNDING

This document is intended to provide education on common Construction Practices for aerial construction of power and telecommunications facilities. This is not an official codebook, nor should it be construed as a construction manual. When constructing aerial facilities, please refer to the governing codes, such as the National Electrical Safety Code, National Electric Code, Oregon Public Utility Commission Safety Rules, Oregon Occupational Safety And Health Administration, State, County and Municipal codes, and all other applicable standards, including contracts.

The 2007 National Electrical Safety Code (NESC) addresses grounds and bonds in Sections 09, 215 and 350

Table of Contents:

- A. Definitions of Bonding
- B. Bonding Installation Considerations
- C. Types of Bond Installations
- D. Types of Bonding Connectors
- E. Definition of Grounded
- F. Grounding Installation Considerations
- G. Types of Grounds
- H. Street Light Grounding
- I. Bonding of Risers

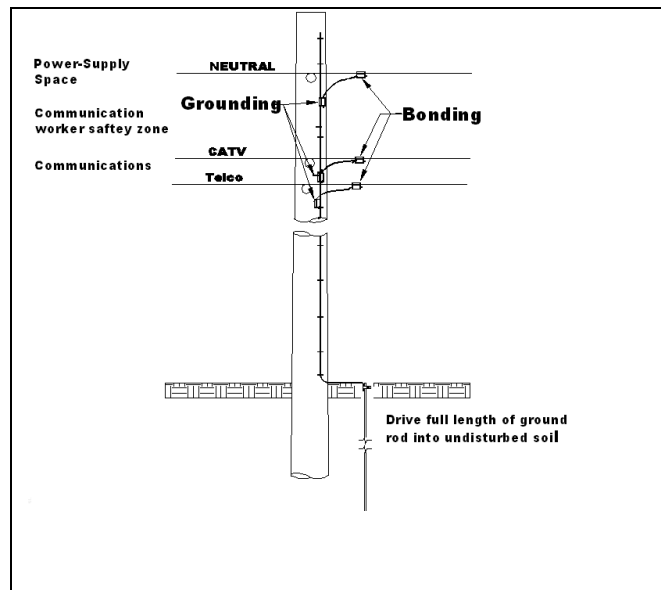

A. DEFINITION OF BONDING: Bonding is defined in the NESC as “The electrical interconnecting of conductive parts, designed to maintain a common electrical potential”.

In other words, bonding can be explained as the permanent joining of metallic parts to form an electrically conductive path that will ensure electrical continuity. Bonding metallic system parts together, offers the capacity to safely conduct any current likely to be imposed on the grounding electrode. Bonding maintains the continuity of the facilities to provide protection of personnel, and equipment.

B. BONDING INSTALLATION CONSIDERATIONS: Aerial cables that include joint use construction will require common bonding. The cables must be bonded together to reduce the electrical power differences (potential).

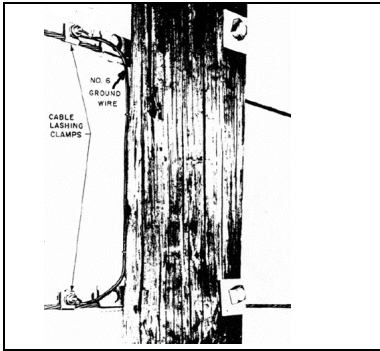

C. TYPES OF BONDS INSTALLATIONS:

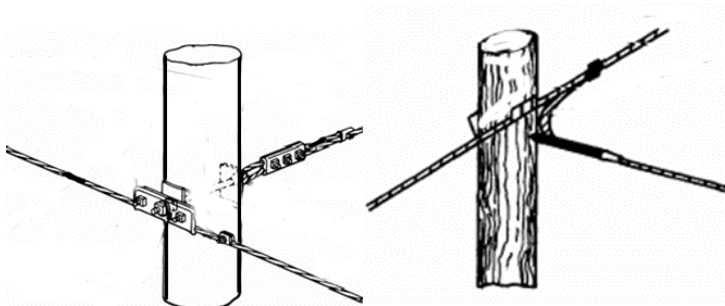

- Tangent with 90 degree tap line

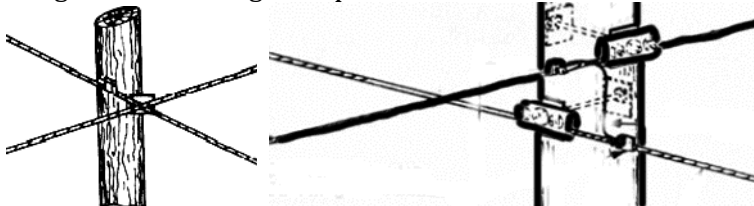

- Intersection of messenger

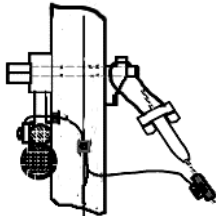





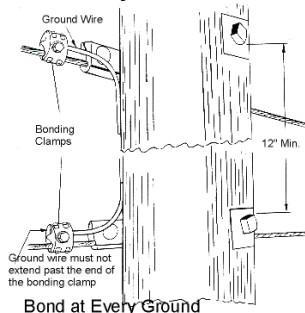

Bond is at the guy

- Down Guy and Anchor

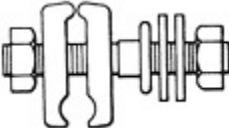

- Parallel Messengers – same company “Weaver”

D. TYPES OF BONDING CONNECTORS:

		
<p>H-2 Connector (Fargo)</p>	<p>C or D-Clamp</p>	<p>Cable Lashing Clamp (Bug Nut)</p>
		
<p>B-Strand Clamp</p>	<p>Ground Rod Clamp</p>	<p>Ground Weaver</p>

E. DEFINITION OF GROUNDED: Grounded is defined by the NESC as “Connected to or in contact with earth or connected to some extended conductive body that serves instead of the earth.

In other words, facilities are grounded when they are purposefully connected by conductive parts to a grounding electrode (ground rod) that is in direct contact with earth – preferably undisturbed. Grounding of facilities is needed for the protection of personnel and facilities from errant electrical faults.

F. GROUNDING INSTALLATION CONSIDERATIONS: The NESC 2007 code requires all joint utility occupiers to ground whenever a vertical ground (pole ground) exists. It is then recommend leaving clearance for other occupiers to attach to ground.

G. TYPES OF GROUNDS:

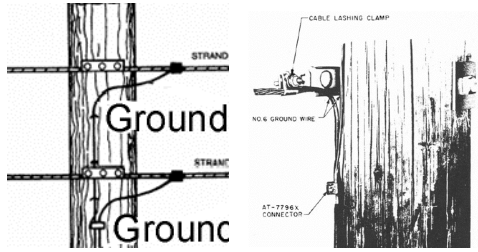

- Aerial Cables

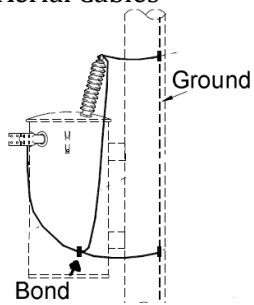

- Transformer and equipment

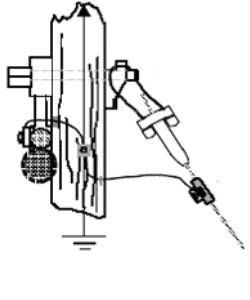
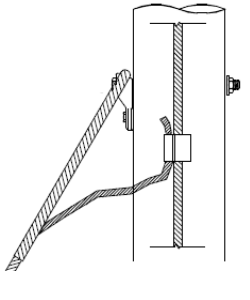
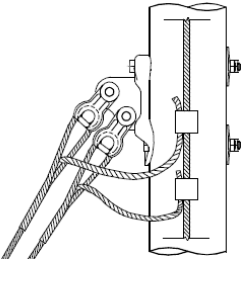

		
Communication Bonding	Power Supply Bonding	Double Down-guy Bonding

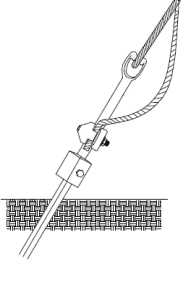
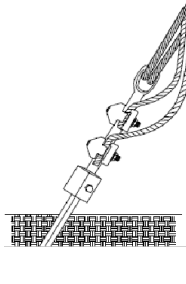
- Guy Grounding

	
Anchor and Guy	Double Down-guy

G. Types of Grounds (cont):

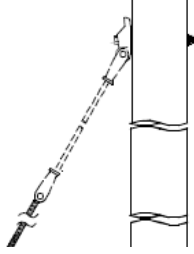
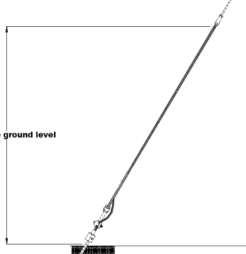
- Anchor Grounding

		
<p>Insulated Guy - Not bonded</p>	<p>Insulated Guy 8 ft min. above ground-Bonded</p>	<p>Porcelain Insulator or "Johnny Ball"</p>



- Guy Strain Insulator
Per NESC 279A, guys must be bonded unless guy insulator is used- then exceptions apply.

H. STREET LIGHT GROUNDING: *Ungrounded* lighting is considered rigid live parts of the voltage they contain and are not shown below. Many utilities use ungrounded street lights and you must be aware of the hazard- it is always best to assume that the street light is not grounded and bonded unless the grounding and bonding is clearly visible.

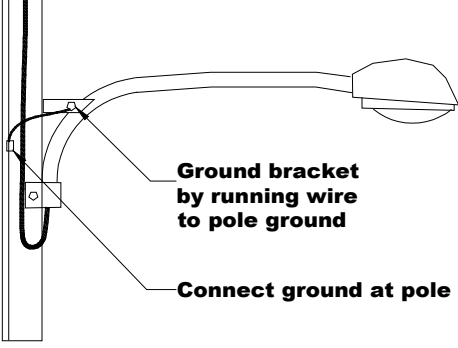
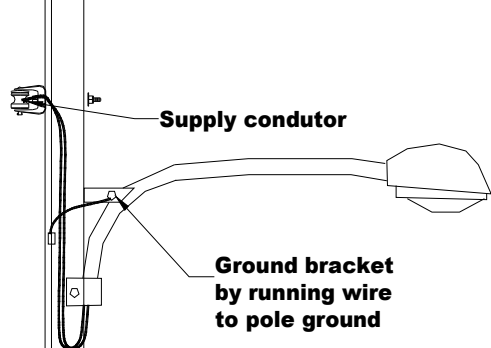
The bonded and grounded lighting (or luminaries) are as follows:

 <p>Ground bracket by running wire to pole ground</p> <p>Connect ground at pole</p>	 <p>Supply conductor</p> <p>Ground bracket by running wire to pole ground</p>
<p>Bonding is from street light arm brace pole ground</p>	<p>Connect streetlight wire secondary supply conductor including neutrals</p>

I. BONDING RISERS: Metal risers must be bonded and grounded if the cables they contain exceed a certain voltage. Generally this voltage is reached only in power cables and is not required by communications. When the communication metal risers are on the same metal brackets as the metal power risers they may also become energized and it is recommend they be bonded. Below are some examples of bonding to metal risers.

		
<p>Bond to pole ground when riser is adjacent to pole</p>	<p>Do not leave ground wire exposed above ground</p>	<p>Wire is bonded to top of metal riser and pole ground</p>

CHAPTER 3 - FRAMING

This document is intended to provide education on common Construction Practices for aerial construction of power and telecommunications facilities. This is not an official codebook, nor should it be construed as a construction manual. When constructing aerial facilities, please refer to the governing codes, such as the National Electrical Safety Code, National Electric Code, Oregon Public Utility Commission Safety Rules, Oregon Occupational Safety And Health Administration, State, County and Municipal codes, and all other applicable standards, including contracts.

The 2007 National Electrical Safety Code (NESC) addresses framing in sections 232, 235, 238

Table of Contents:

- A. Definition of Framing
- B. Site Specific Construction
- C. Types of Framing
- D. Avian Protection Construction
- E. Construction Practices
- F. Ground Clearances
- G. Voltage Clearances

A. DEFINITION OF FRAMING: Framing is not defined in the NESC. In this document ‘Framing’ is referring to the overhead installations of poles and some other utility structures such as transmission H structures and the facilities attached to them. It is basically the construction style that best suits certain conditions determined by generally accepted practices

B. SITE SPECIFIC CONSTRUCTION: The specific requirements at a specific structure (pole) require different types of framing. These types include, but are not limited to:

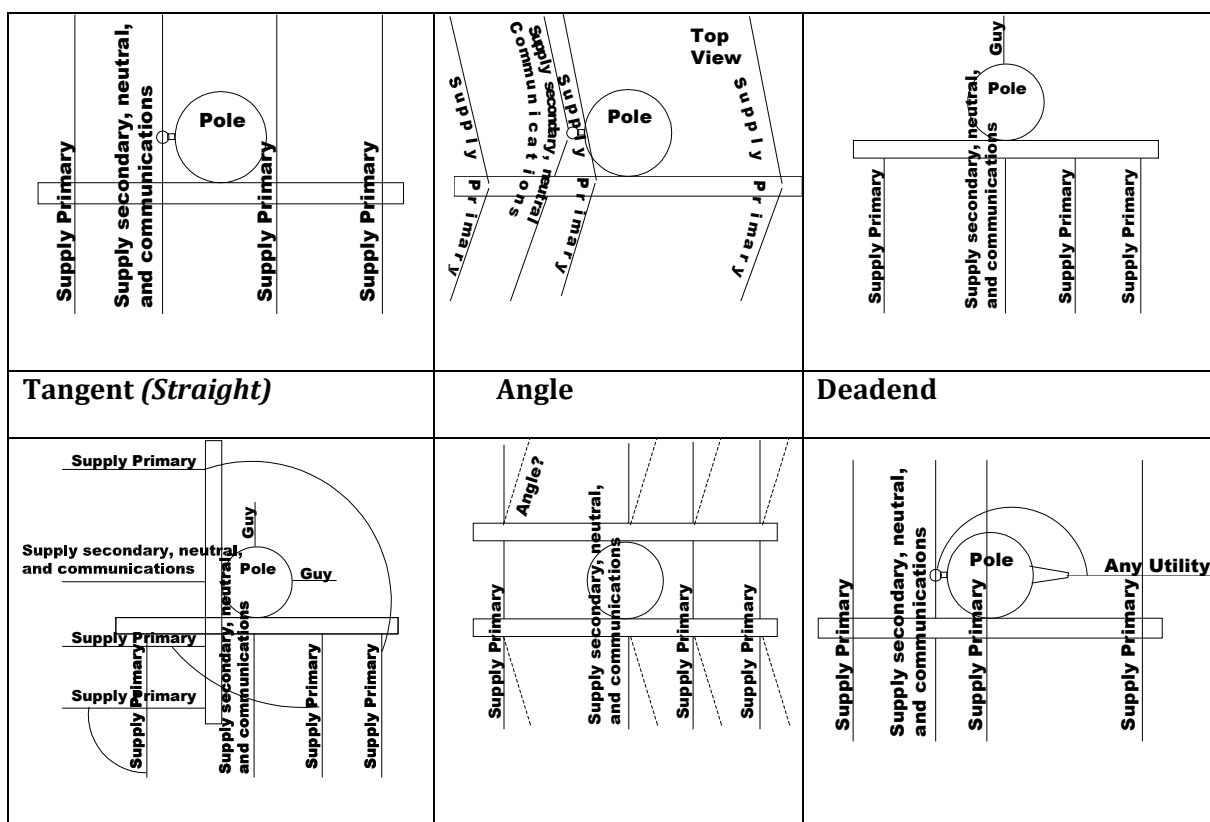

C. TYPES OF FRAMING: All types of Supply Construction cannot be listed here. The examples given represent a generally accepted preference of construction.

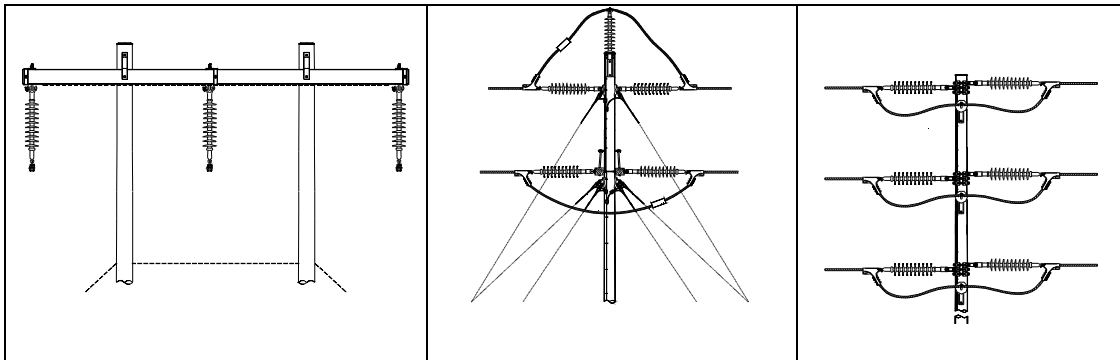

- Transmission Only

<p>Transmission with Primary Underbuild and Secondary</p>	<p>Transmission with Primary Underbuild and Supply Fiber</p>	<p>Transmission with Primary Underbuild and Typical Joint Use</p>

- Transmission with Primary

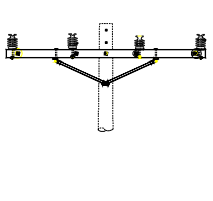
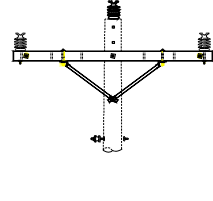
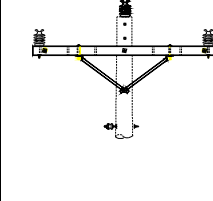
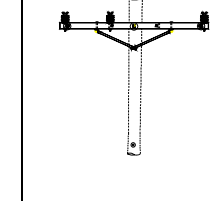
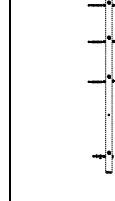
				
Flat	Pole Top Insulator (PTI)	High-low neutral	Low Neutral	Vertical

- Primary Only

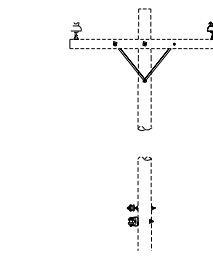
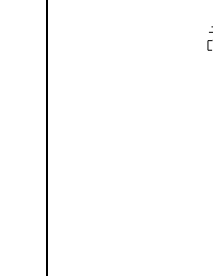
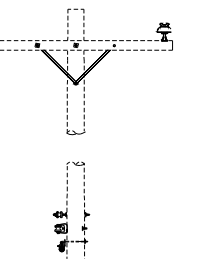
		
Primary with Secondary	Primary with Secondary with Supply Fiber in the Supply Space	Primary with Secondary and Communications

- Primary with Secondary

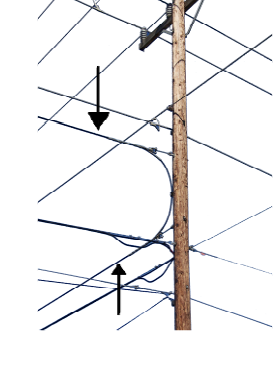
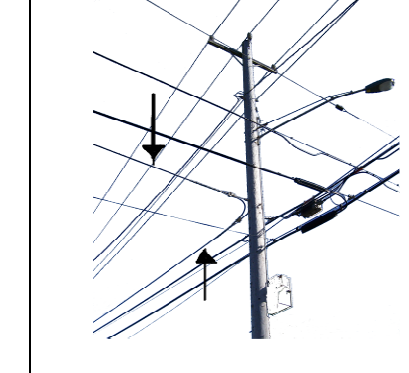
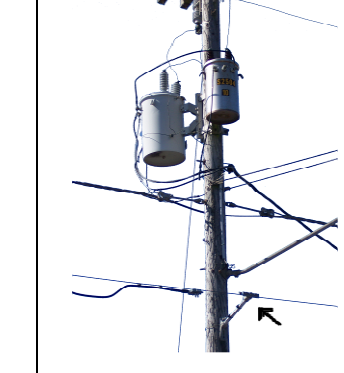
		
Primary with Supply Fiber in the Supply Space and Com. space	Primary with Supply Fiber in the Communication Space	Supply Fiber in Communication space on bracket

- Primary with Secondary and Supply Fiber

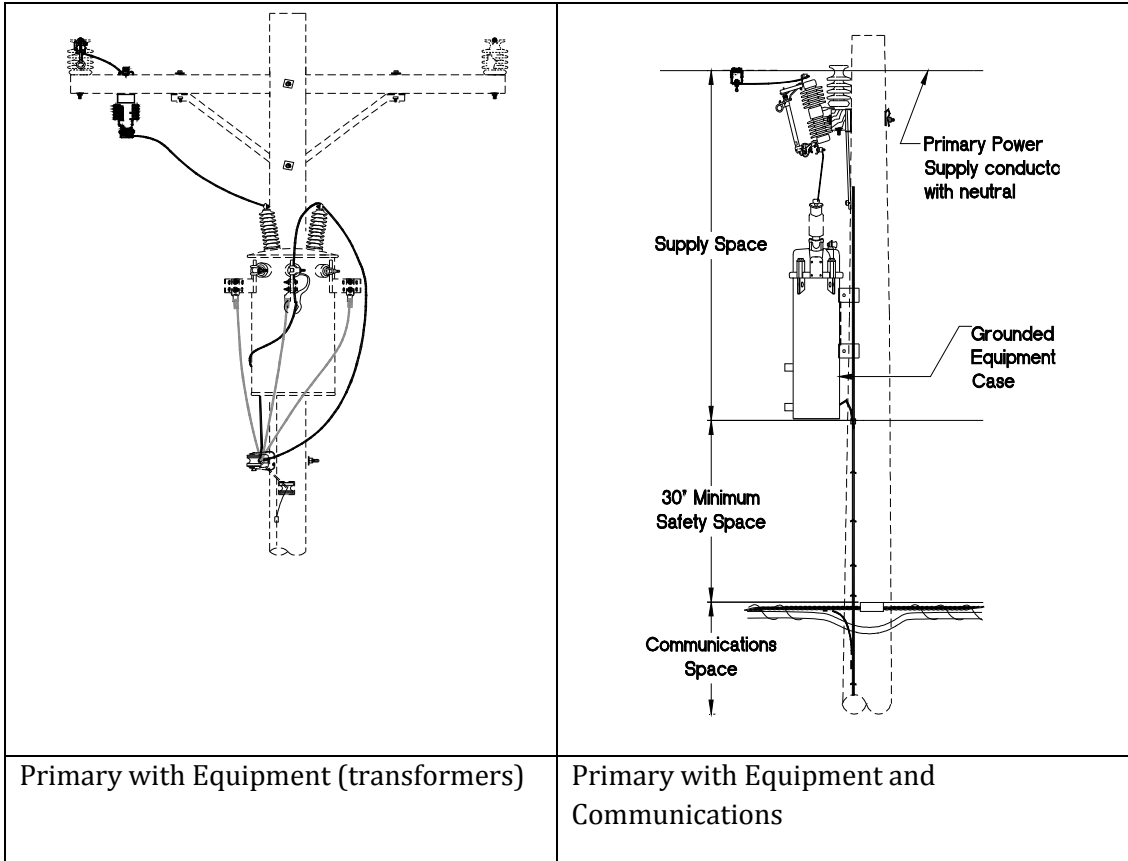

- Primary with Equipment

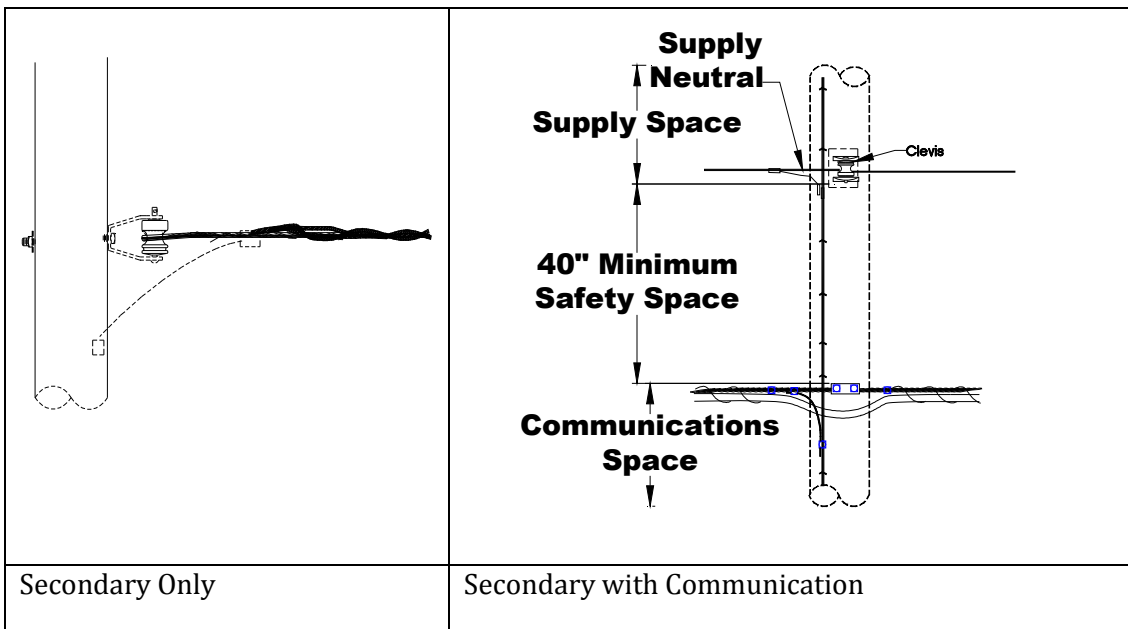

- Secondary

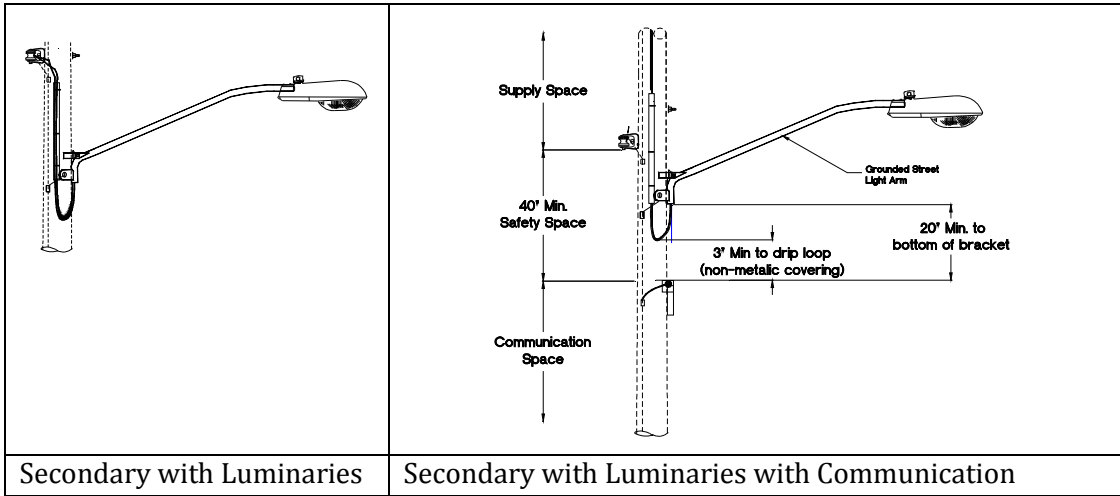

- Secondary with Luminaries (Streetlights)

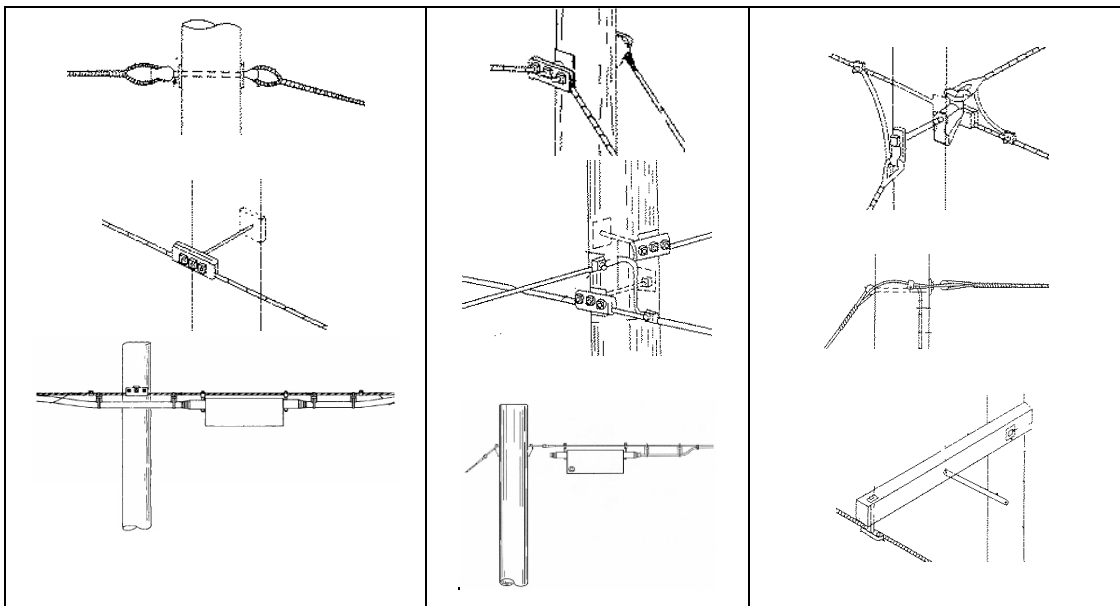

Communication Only

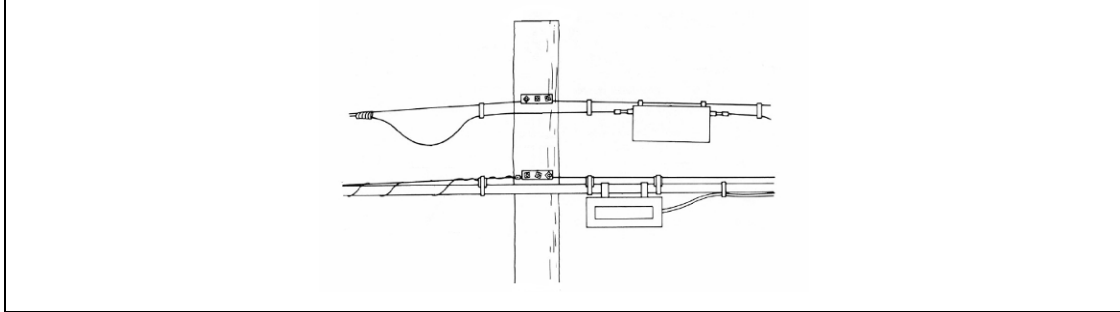

Communication to Communication

- Communication Only

Note: See chapter on Support Arms

D. AVIAN PROTECTION CONSTRUCTION: In recent years there has been a growing concern regarding the protection of migratory birds. The U.S. department of Fish and Wildlife has required many supply companies to provide an Avian Protection Plan. This plan may require greater spread between conductors. The supply utility may lower the conductors to provide fowl wingspread.

E. CONSTRUCTION PRACTICES: There are some generally accepted rules based on the NESC as to where supply and communication attach to structures (poles). As with all construction, there are exceptions.

Normally the attachments for new construction are from top to bottom as follows

- Supply Transmission
- Supply Primary - 10 ft minimum below Transmission
- Supply Secondary – 6 ft minimum below Primary
- Supply Fiber – can also be above secondary
- Communication TV – 40 inches below supply cables
- Communication Telco – 40 inches below supply cables and 12 inches below TV
- Communication to Communication 12 inch separation

Note: Suggested practice is to follow the existing framing for new attachments and construction.

Example: *If the existing neutral or communication aerial cable is on the road side – new aerial cables should be installed on the road side.*

F. GROUND CLEARANCES: Clearances of attachment heights vary, depending on the clearance of the cable or conductor to ground. NESC table 232-1 gives detailed minimum ground clearances for both supply and communications. However there are other jurisdictions that may require greater heights.

Below is an example of road districts that require more than the minimum NESC code.

Minimum Clearances Over Road													
Vert Feet	State			County									
	ODOT			Coos		Lane		Lincoln		Douglas			
24													
22													
20													
18													
16													
15½													
12													
11													
8													
3½													

	Crossing
	Parallel
	Sag-crossing
	Communications

Clearances are measured from surface to surface

G. VOLTAGE CLEARANCES: Per NESC table 235-5 the minimum height of an attachment is often the result of the voltage of the conductors above it. For example, the minimum height on a supply pole that the primary conductor can attach is dependent on the voltage of the transmission conductor above it. Similarly the height at which a communication cable may be attached is dependent on the voltage of the supply cable above it. This voltage is not determined simply by a visual observation.

Here are some different methods for determining attachment heights:

- Inquire to the supply utility as to the voltage and use NESC table 235-5
- Request permit attachment height from supply utility
- Pole is marked or banded to show communications maximum attachment height

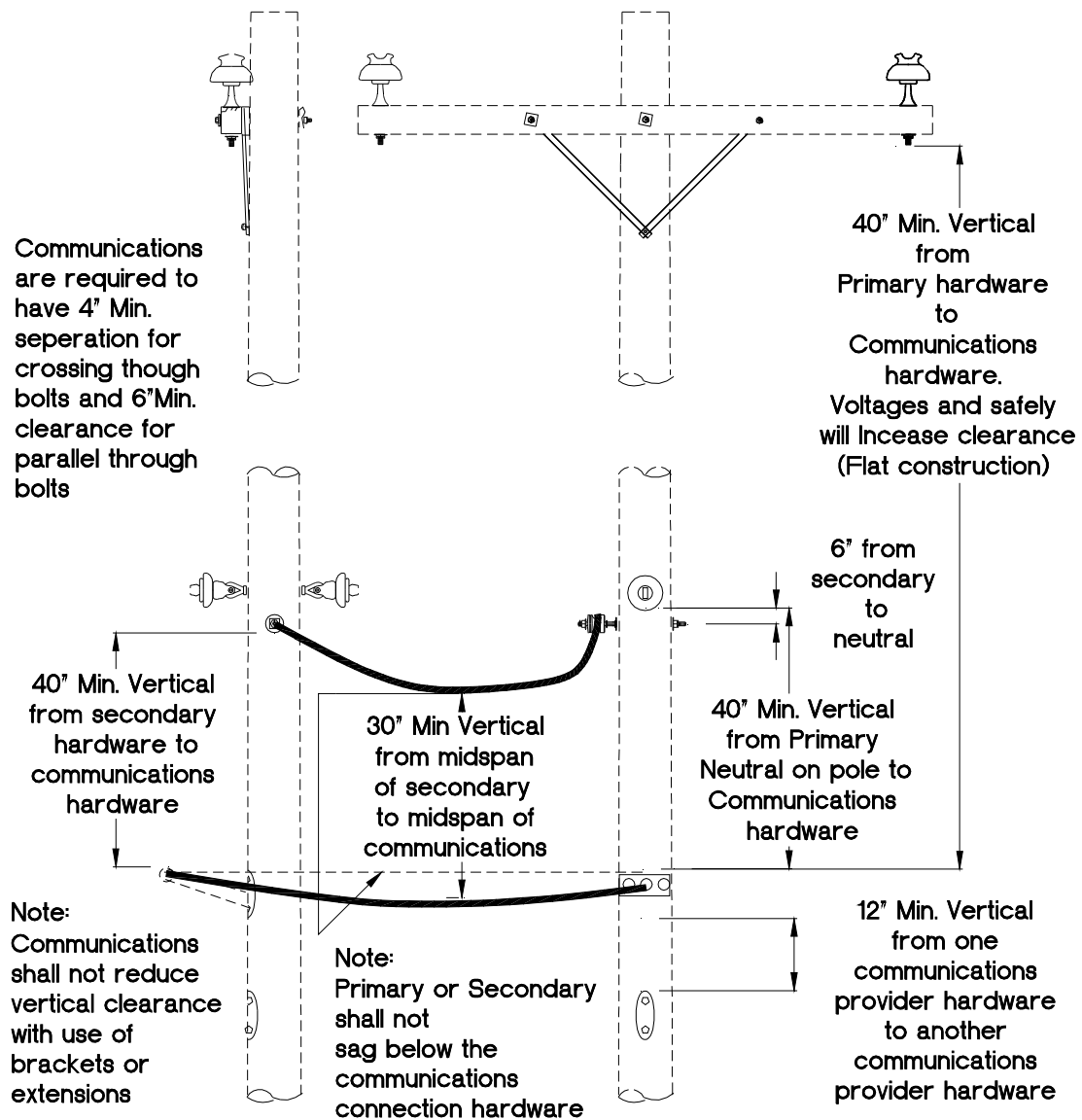

Note: Mid-span clearances are a controlling factor- see chapter on Sag and Tension.

CHAPTER 4 - POLES

This document is intended to provide education on common Construction Practices for aerial construction of power and telecommunications facilities. This is not an official codebook, nor should it be construed as a construction manual. When constructing aerial facilities, please refer to the governing codes, such as the National Electrical Safety Code, National Electric Code, Oregon Public Utility Commission Safety Rules, Oregon Occupational Safety And Health Administration, State, County and Municipal codes, and all other applicable standards, including contracts.

The 2007 National Electrical Code (NEC) addresses poles throughout the code.

Table of contents:

- A: Definition
- B: Placement
- C: Types
- D: Identification
- E: Grades of Construction
- F: Pole Class
- G: Pole Top Extension
- H: Pole Supports

A. DEFINITION OF A POLE: NEC defines poles as “Structures used to support supply and or communication conductor cables and associated equipment”.

B. PLACEMENT: The placement of poles is subject to numerous conditions, such as the general location and proximity to the street, buildings, fire hydrants, driveways or easements and other aerial or buried utilities. Additional factors to consider are the weight loading for the pole, the depth the pole is to be set, protective barriers that may be needed, foliage in the vicinity that may need to be trimmed, and local climate (snow and or wind loads). As with any excavation, utility locates must be made.

C. TYPES:

- **Wood:** The most predominate species of wood used for poles consists of Western Red Cedar, Douglas Fir, various species of Pine and Western Larch. Typically wood poles are treated to prevent deterioration and rot; common treatments can be Copper Naphthenate or Pentachloraphenol. The species of wood and the treatment used can usually be found on the brand or tag that the supplier places on the pole.
- **Metal:** Tubular metal poles are typically made from galvanized steel or aluminum
- **Concrete:** Designs for concrete poles include tapered structures and round poles made of
 - Solid Concrete
 - Pre-Stressed Concrete
 - Hybrid – Concrete and Steel Poles
- **Fiberglass:** Poles are hollow and similar to the tubular metal poles with a typical fiberglass thicknesses of ¼ to ½-inch

- **Laminate:** An Engineered product comprised of assemblies of specifically selected and prepared wood laminates bonded with adhesives and treated with preservatives.

D. IDENTIFICATION: Metal Tags (bellybutton) or Stamp (burned branded)

- **Stamp:**

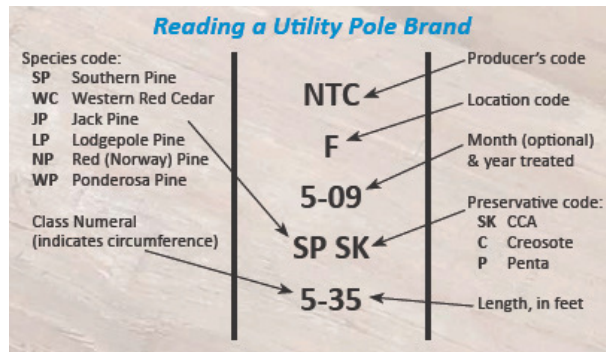

- **Metal Tag**



- YEAR
- CLASS
- HEIGHT
- MATERIAL & TREATMENT

E. GRADES OF CONSTRUCTION: The Grade of Construction will determine the appropriate size (strength) pole to withstand wind and ice storms to meet basic safety requirements. Three grades of construction are defined by the NESC related to pole lines:

- Grade B -- the highest grade; typically corresponds to crossings (highway, railroad, pole lines carrying varying power supply voltage levels...)
- Grade C -- lower grade of construction than Grade B; typical power or joint-use (telecommunications and power) distribution pole applications
- Grade N -- lowest grade of construction; typically only used on poles with sole use of communication facilities

F. POLE CLASS:

Wood Pole Class	Horizontal Load (lb)	Length Range (ft)	Minimum Tip Circumference (inch)
H6	11,400	45-125	39
H5	10,000	45-125	37
H4	8,700	40-125	35
H3	7,500	40-125	33
H2	6,400	35-125	31
H1	5,400	35-125	29
1	4,500	35-125	27
2	3,700	20-125	25
3	3,000	20-90	23
4	2,400	20-70	21
5	1,900	20-50	19
6	1,500	20-45	17
7	1,200	20-35	15
9	740	20-30	15
10	370	20-25	12

Utility poles are divided into classes. The classes' definition specifies a minimum circumference that depends on the species of tree and the length of the pole. This circumference is measured 6 feet from the butt of the pole. There is also a minimum top circumference that is the same for all species and lengths.

For example, a class 1 pole has a minimum top circumference of 27 inches. If it is 25 feet long and cedar (most utility poles are cedar), the circumference measured 6 feet from the bottom must be at least 43.5 inches.

The higher the class number, the skinnier the pole. Pole lengths start at 16 feet and increase by 2-foot steps to 22 feet, then by fives from 25 feet to 90 feet. A 90-foot class 1 western red cedar pole weighs about 6,600 pounds. A 16-foot pole weighs only about 700.

Standards (from ANSI) severely limit or exclude various types of damage, including bird holes and insect boring, and describe ways of specifying the pole's straightness.

On curves, hillsides, or other locations where there's an unbalanced pull on the pole, standard practice calls for increasing the portion of the pole that is buried. For example, for poles being set along a straight line, 6 feet of a 35-foot pole would be buried, but if the pole were on a curve, 6.5 feet.

A 35-foot pole is a typical length used in cities to carry one or two crossarms. Poles are spaced about 100 feet to 150 feet apart, with 125 feet being typical.

The class of the pole should not be confused with the grade of construction.

G. POLE TOP EXTENSIONS

- Fiber glass



- 4x4 (California arm)



H: POLE SUPPORTS:

- Swamp brackets (legs)

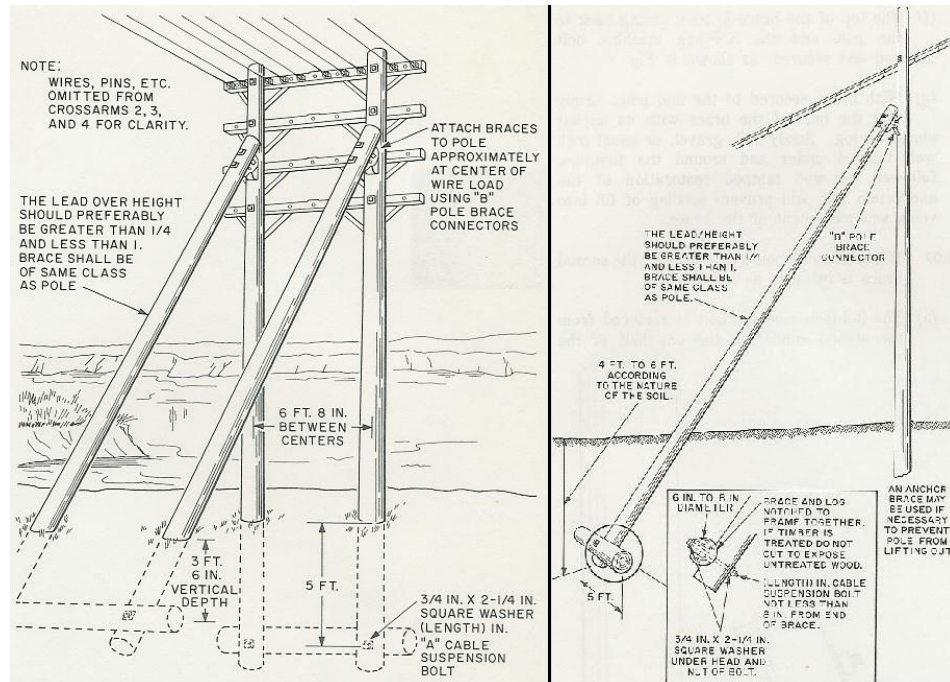

- Guys

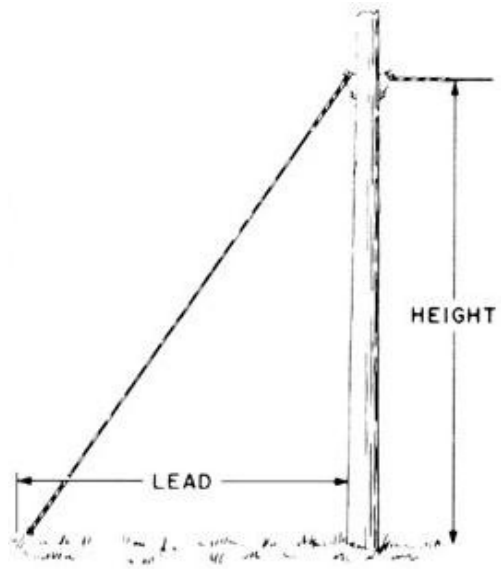

- C Trussing

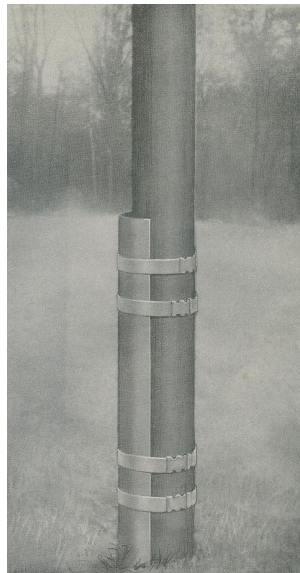

- Pole strapped to pole

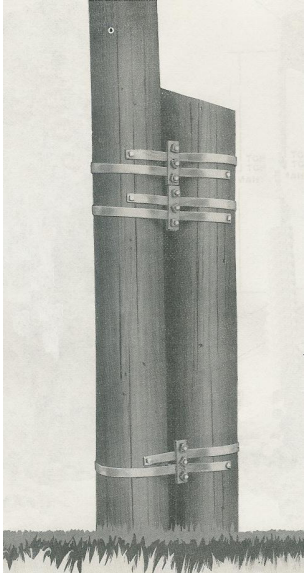

- Push pole

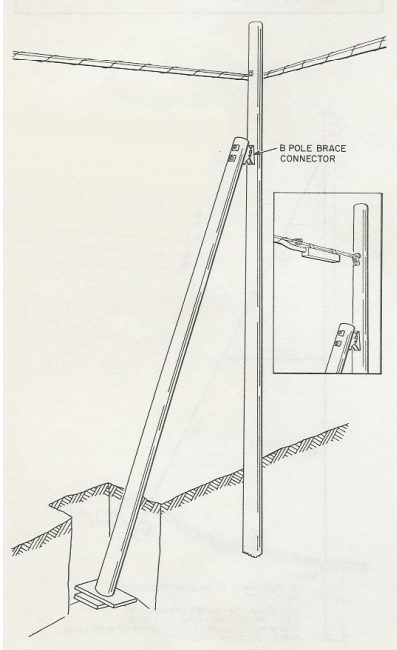

CHAPTER 5 - RISERS

This document is intended to provide education on common Construction Practices for aerial construction of power and telecommunications facilities. This is not an official codebook, nor should it be construed as a construction manual. When constructing aerial facilities, please refer to the governing codes, such as the National Electrical Safety Code, National Electric Code, Oregon Public Utility Commission Safety Rules, Oregon Occupational Safety And Health Administration, State, County and Municipal codes, and all other applicable standards, including contracts.

The 2007 National Electric Safety Code (NESC) addresses Risers in Sections 360, 361, 362, & 239D

Table of Contents:

- A. Definition of Risers
- B. Placement consideration
- C. Types of Mechanical Protection
- D. Installation
 - Direct Attachment
 - Stand Off

A. DEFINITION OF RISER: A vertical installation of a cable or conductor that is directly or indirectly (stand-off brackets) attached to a pole for the purpose of transitioning between Aerial and Underground system. A vertical ground should not be considered a riser. The term riser references either cable or the mechanical protection (conduit, u-guard, etc.)

B. PLACEMENT CONSIDERATIONS:

- Mechanical protection for supply conductors or cables is required by NESC Rule 239D. This protection should extend at least (one foot) below ground level.
- Communication cables and armored cables that are firmly secured to the pole do not require guarding.
- For mechanical protection risers should be installed on the pole quadrant away from the flow of the traffic and in the safest available position with respect to climbing space. (see Figure 1)
- Observe climbing space. The number, size, and location of risers shall be limited to allow adequate access for climbing. Vertical runs physically protected by suitable conduit and securely attached to the surface of the line structure are not considered to obstruct the climbing space.
- Existing risers should not obstruct other equipment or prevent the attachment of additional facilities.
- Supply cable conduits should extend far enough above communication facilities to provide for a 40" clearance from drip loops to communication facilities.
- Exposed conductive pipes or guards containing supply conductors or cables shall be grounded in accordance with Rule 314 (grounding of circuits & equipments).

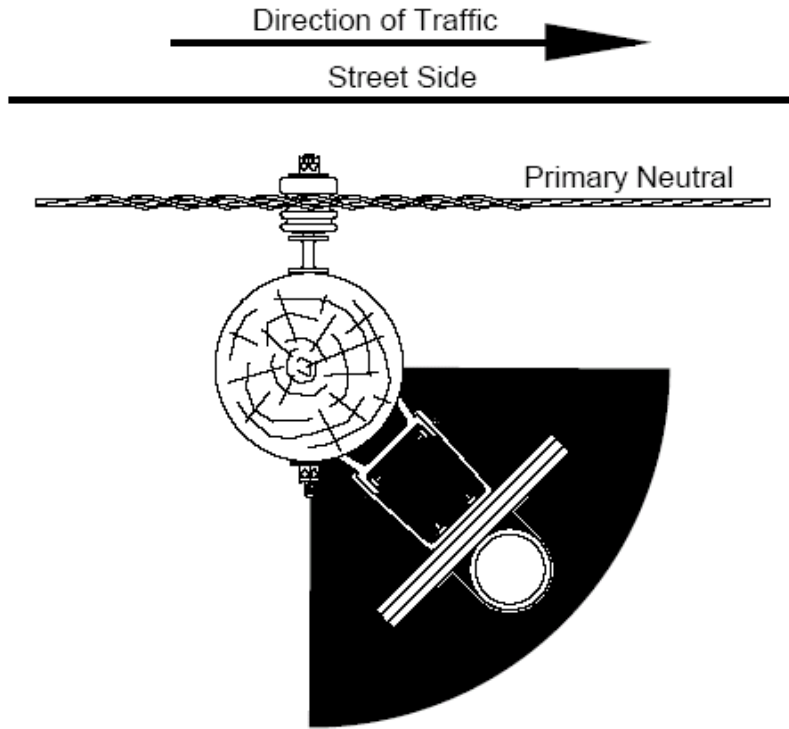
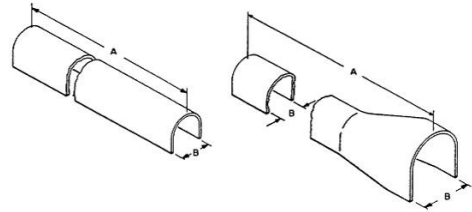

Figure 1 - Preferred Riser Placement

C. Types of Mechanical Protection

- U-Guard
 - Plastic
 - Metal
 - Wood



- Conduit
 - Plastic or Metal

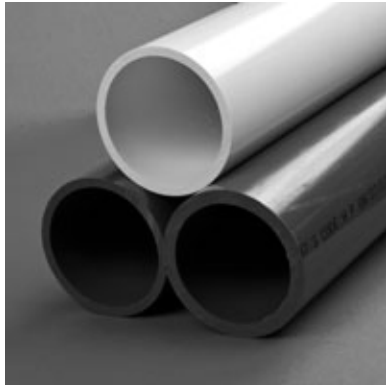

- Split

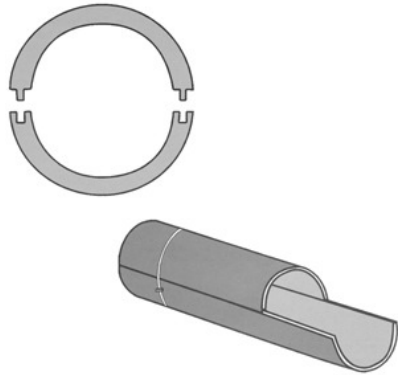

- Flex



- CIC (Cable in Conduit)



Installation:

- The first riser bracket should be a minimum of 8' above ground or 8' to the next climbable surface (see NESC 217A2c)
- Maintain space requirement from the pole to facilitate a lineman's ability to climb and belt off on the pole. (see Figure 1)

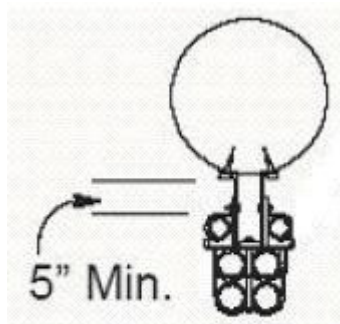
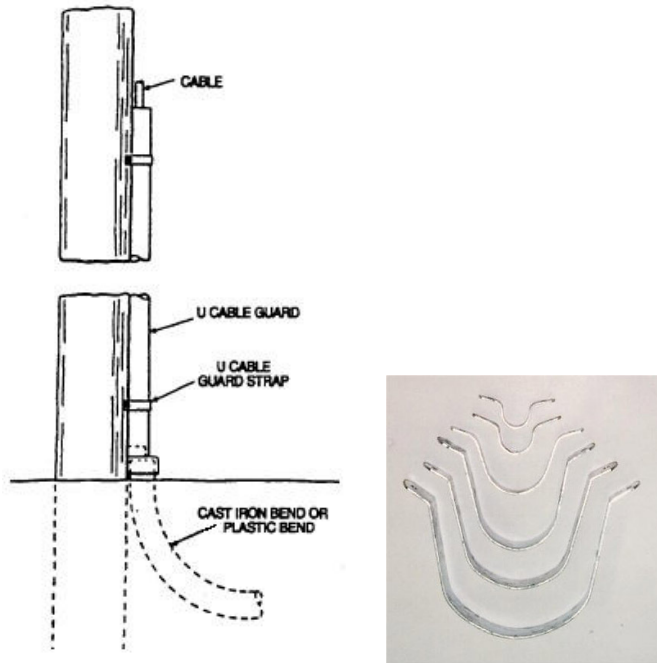

Figure 1

Riser conduits can be directly affixed to the pole by utilizing one of the following devices spaced in a manner to maintain its installed position.

- Direct attachment to pole with conduit clamps.



- Attachment to stand off brackets with conduit clamps



CHAPTER 6 - TENSION AND SAG

This document is intended to provide education on common Construction Practices for aerial construction of power and telecommunications facilities. This is not an official codebook, nor should it be construed as a construction manual. When constructing aerial facilities, please refer to the governing codes, such as the National Electrical Safety Code, National Electric Code, Oregon Public Utility Commission Safety Rules, Oregon Occupational Safety And Health Administration, State, County and Municipal codes, and all other applicable standards, including contracts.

The 2007 National Electrical Safety Code (NESC) addresses Tension and Sag in Sections 235, 251, 252, 253, 261, 263, and 277

Table of Contents:

- A. Definitions of Tension and Sag
- B. Engineering Design Description
- C. Methods of Tensioning
- D. Reduced Tension Construction
- E. Guy Tension
- F. Line of Site
- G. Sag Charts
- H. Loading Zone
- I. Grades of Construction
- J. Resources

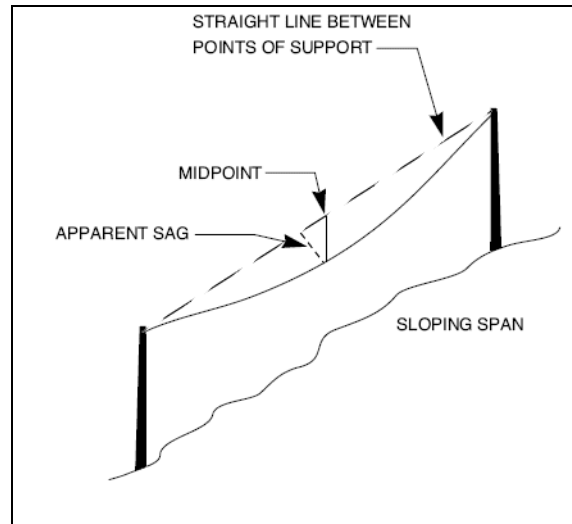

A1. DEFINITION OF TENSION: Tension is defined in the NESC as “The longitudinal force exerted on a cable during installation”. In other words tension can be explained as force pulling the cables or wires at either end by what they are attached to or the weight of the cable itself.” Tension is also applied to insulators.

There are two main types of tension

- Initial tension is defined in the NESC as “The longitudinal tension in the conductor prior to the application of any external load”. In other words, the characteristics of the cable before time, temperature, weight etc. of the conductor stretch or shrink the wire.
- Final tension is defined in the NESC as “The longitudinal tension in a conductor after it has been subjected for an appreciable period of the loading prescribed for the loading district in which it is situated, or equivalent loading, and the loading removed.” In other words, what the characteristics of the cable are expected to be after time, temperature, weight and other factors have affected it.

A2. DEFINITION OF SAG: Sag is defined in the NESC as “The distance measured vertically from a conductor to the straight line joining its two points of support.” In other words, sag is usually the lowest point on a cable or wire between two points. This low point is measured as though there were a straight line between the attachment points on either end and the distance between this low point and the straight line is the sag.



B. ENGINEERING DESIGN: The appropriate sag and tension is determined by

- Span lengths
- Strand size
- Load
- Storm loading area
- Temperature
- Vertical clearances above grade
- Vertical clearances from other utilities
- Pole lengths
- Class of pole

C. METHODS OF TENSIONING:

Types of Tensioning

- Dynamometer

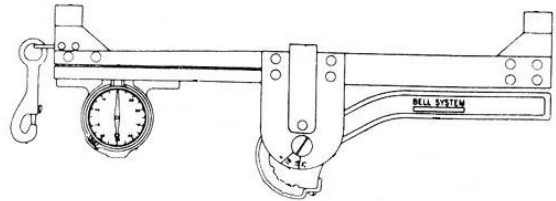
		<p>Dynamometer are the preferred method for testing tensioning</p>
<p>Electronic</p>		
		
<p>Mechanical</p>		

- Third wave return

	<p>A light rope tossed over the conductor near one end of a span and give it a good hard jerk down. At the same instant press the button on the watch to start it. You then feel for return pulses in the rope as the shock wave you created runs up and down the conductor. At the instant you feel the third or fifth return you stop the watch. Read the number on the appropriate scale on the face of the watch and you have your sag in feet. The scales are direct reading and no math is needed.</p>

- Matching sag

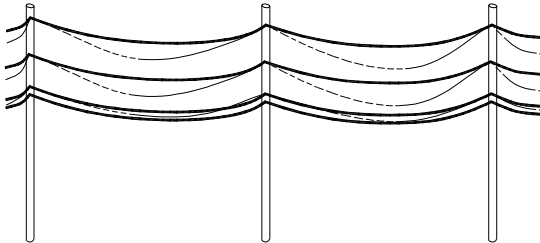
	<p>The smaller cables represent the difference in sag after environmental changes- notice how the sag between conductors differs.</p> <p>NESC clearances may not be met during different temperatures, ice, wind, etc. or over time.</p>
<p>This method is not recommended</p>	

D. SLACK SPAN (REDUCED TENSION CONSTRUCTION): Slack Spans are used when traditional guying is not practical. This should be avoided if possible. The Slack Spans are typically limited to one span and sags of joint users are matched. Guying can also be avoided with the use of stronger poles.

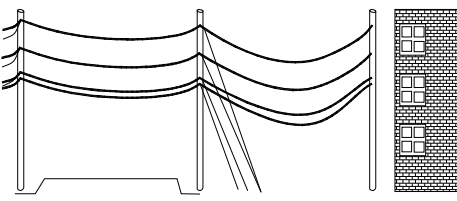
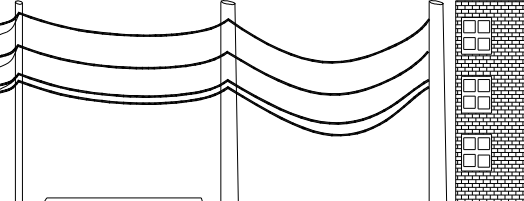
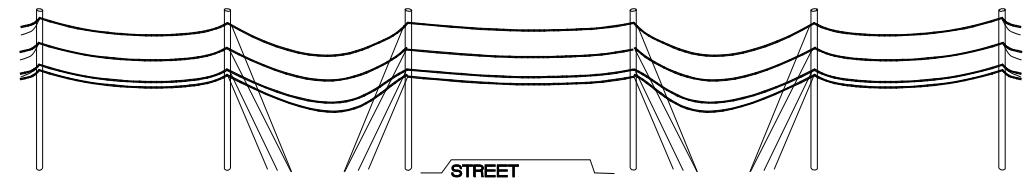
	
<p>Guying in same direction</p>	<p>Using larger class pole</p>
	
<p>Double Slack Span to provide corner poles and street clearance</p>	

E. GUY TENSION: Per NESC 261C2 (in layman’s terms) the guy should be considered a part of the structure and designed and installed with the proper tension to support the tension of the attachments it supports. The guy can create an imbalance in tension if installed too tight. The note for this section also clarifies that guys must not be “loose”.

F. LINE OF SIGHT: Per NESC 235C3 (in layman's terms) primary power cables cannot sag below the attachment points of the highest communication cable in spans over 150 feet.

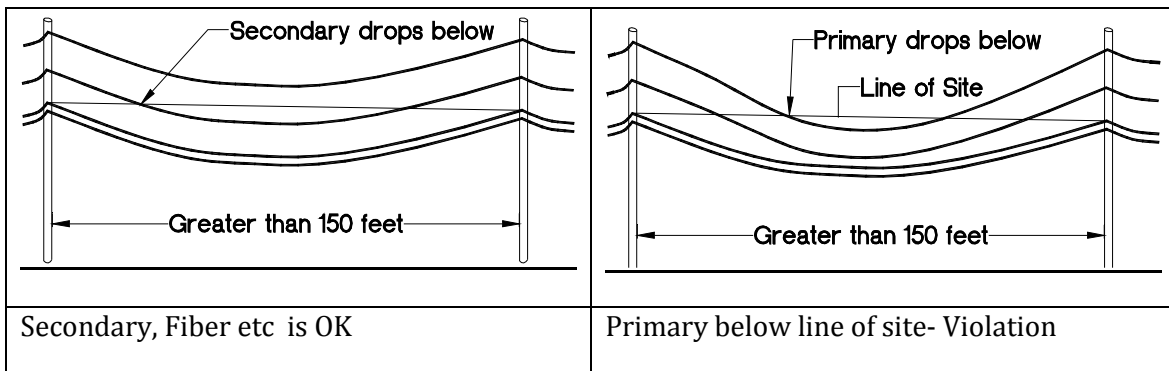

G. SAG CHARTS: Sag Charts are used by most aerial utilities in one form or another to determine how much tension to use to pull the wire up to the appropriate sag. They come in many forms based on a variety of formulas. Some are commercially provided like those mentioned in Resources, some are created in house. They all consist of some basic information:

- Wire Diameter
- Span Length
- Wire Weight
- Supporting Cable Characteristics
- Temperature
- Rated Breaking Strength
- Tension

H. LOADING ZONE: Varying environmental conditions create hazards that effect aerial cables differently. When looking at the United States Map the loading zone appears that all of Oregon has a “Medium” loading zone. Special Wind Regions change the standard “Medium” Loading Zone to “Extreme” loading. There are 34 types of loading zones Heavy, Medium, Light and Extreme.

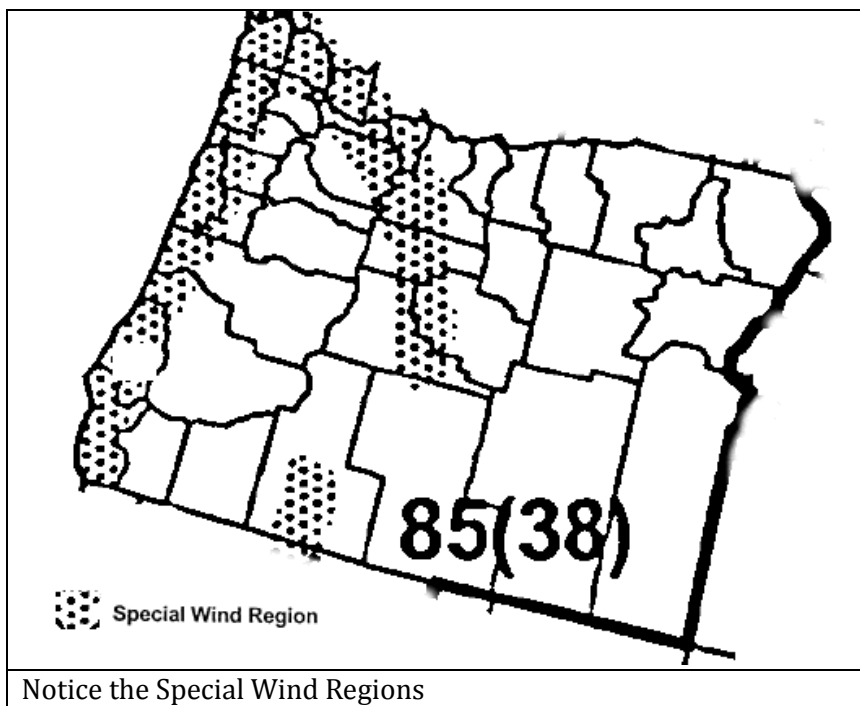
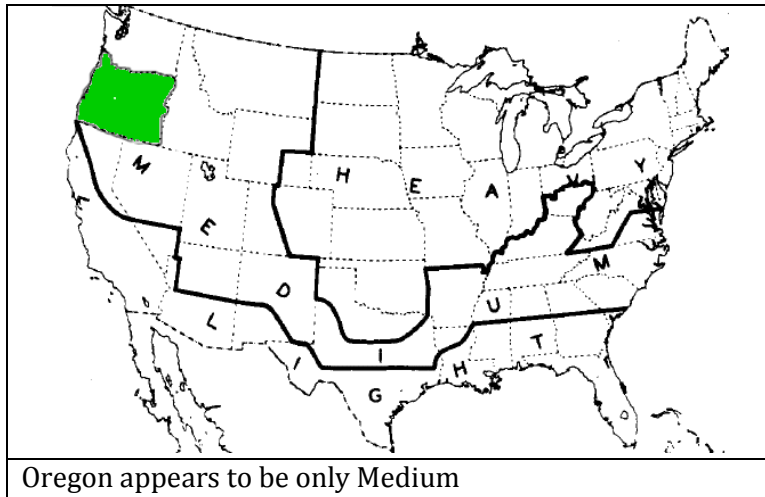

Normally Oregon can expect 85 mile winds- however in “Extreme” areas those winds may increase to 120 miles or more. The Loading Zone or district determine some of the overload factors used for engineering.

H. Loading Zone (cont.)

- **Heavy** Loading Districts are generally in the central and northeast U.S. states. There is an assumption of lower temperatures and greater ice buildup on cables and conductors. This may require adjustments made such as open-wire conductors having breaking strength reduced by 50%. Where there are copper or steel cables or conductors span lengths should be kept to a minimum
- **Medium** Loading District covers much of the northwestern states including Oregon. Where the standard for ice in the Heavy Loading District is $\frac{1}{2}$ inch, in the Medium zone it is assumed $\frac{1}{4}$ inch. This may require adjustments are made. One example is an open-wire conductors having breaking strength reduced by 33%. Where a limiting span length in the Heavy zone is 150 ft it may be increased to 175 in a Medium or Light zone.
- **Light** Loading District covers most of the southern USA. It has the lightest, most flexible loading zone. Where the Medium Loading District assumes $\frac{1}{4}$ of ice. The Light Loading District assumes no ice.
- **Extreme** Loading District covers the entire coast, Columbia Gorge and some other areas of Oregon. This zone does not have ice but has higher than usual winds. The current code assumes wind above 60 feet must withstand extreme wind. The 60 feet exception will likely be removed in the NESC 2007 code.

I. GRADES OF CONSTRUCTION: There are 3 types of grades of construction. Above ground utility construction must meet one of the 3 depending on environmental concerns.

- **Grade N** construction per NESC 263 is the most reduced type. Per NESC 014A2 grade N may be used for emergency construction. This construction must be upgraded to Grade C or above as soon as possible. Construction must always meet the minimum of grade N. A planned Grade N construction may be required when installing and removing facilities overlap. Planned Grade N requires approval of the OPUC. Grade N does not usually apply to communication facilities where no supply facilities exist. (NESC 263G)
- **Grade C** construction is the most common type of construction. Grade C provides the standard of minimum requirements for items such as strength of poles, structures, hardware, cross-arms, guys, anchors, foundations and sizes and sag for supply conductors. Grade C also provides the overload factors needed to meet the minimum standard.
- **Grade B** is the highest or most stringent type of construction. Grade B provides the standard of minimum requirements at greater values than Grade C. This type of construction is the minimum for installations crossing over railroads, communication lines or limited access highways. It is also used when the high voltage of the supply conductor will not be de-energized during breaker operations. Grade B may be used in Extreme Wind loading areas. Grade B has more stringent strength and overload factors than either grade N or C. Engineering for Grade B may require doubling cross-arms, brackets, ties and pins.

I. RESOURCES:

- Alcoa Sag 10 (Supply Cables)
- CommScope (Communication Cables)
- NESC 2007

CHAPTER 7 - SUPPORT ARMS

This document is intended to provide education on common Construction Practices for aerial construction of power and telecommunications facilities. This is not an official codebook, nor should it be construed as a construction manual. When constructing aerial facilities, please refer to the governing codes, such as the National Electrical Safety Code, National Electric Code, Oregon Public Utility Commission Safety Rules, Oregon Occupational Safety And Health Administration, State, County and Municipal codes, and all other applicable standards, including contracts.

*The 2007 National Electrical Safety Code (NESC) addresses Support Arms in Sections 232B, 243B; 72, 160

Table of Contents:

- A. Definition of Support Arm
- B. Placement considerations
- C. Types
- D. Braces
- E. Lengths
- F. Pole Gains
- G. Installation

A. DEFINITION OF SUPPORT ARM: Apparatus made of wood (which may require bracing), fiberglass, or steel that is bolted directly to the pole for the purpose of attaching equipment, messengers or conductors.

- Establish or maintain clearances
- Maintain the lead or tangent (eliminate the necessity to guy a pole)
- Create space to accommodate multiple attachments
- Create climbing space

B. PLACEMENT CONSIDERATIONS: Considerations include length, weight of facilities, angle, type of arm, clearance from the pole and ground, space on the pole, and size of the arm.

(Note: Communication operators typically will not place a support guy on a support arm)

C. TYPES:

- Metallic communication alley arm

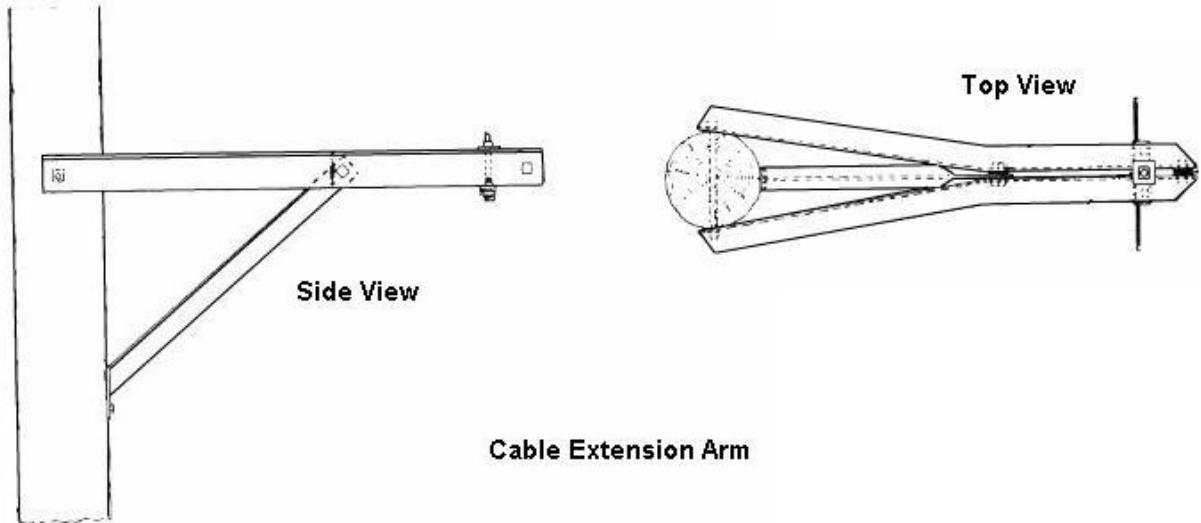

- Seattle bracket (extension bracket)

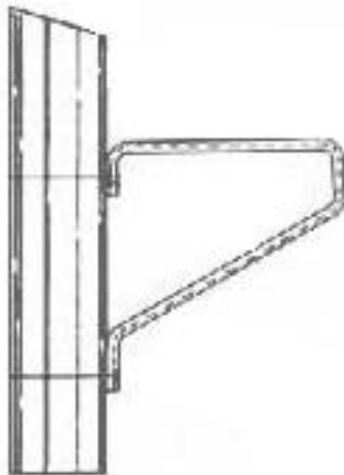

- T-alley bracket

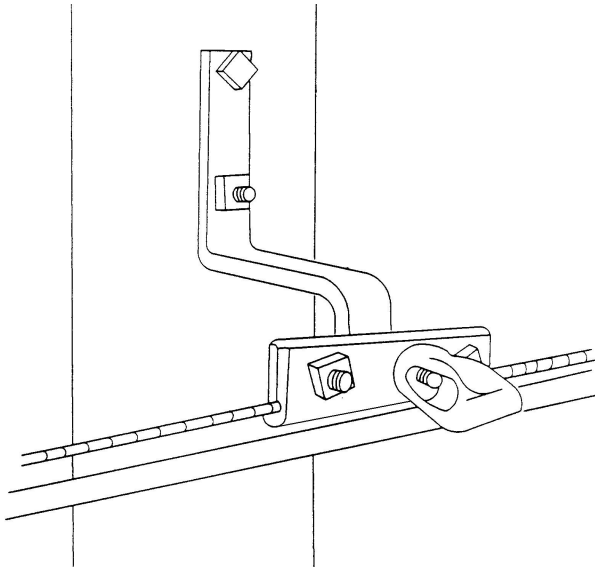

- Flying Mary (support made of strand - also known as Flying Dutchman)

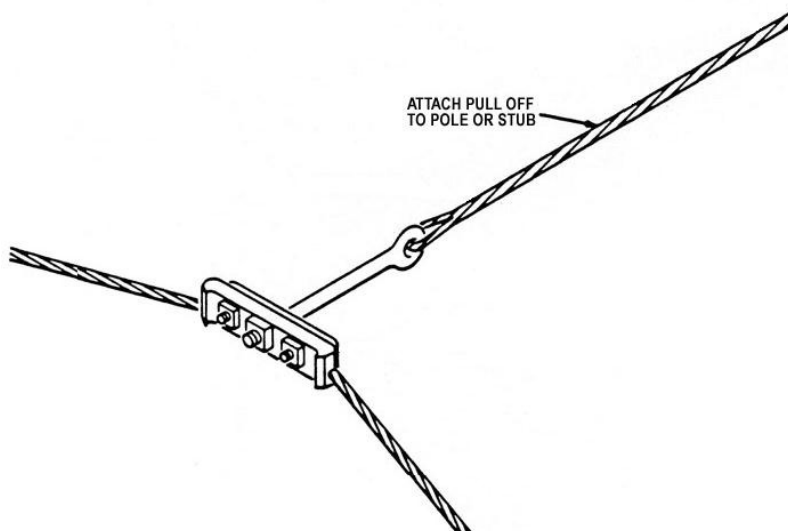

- Illinois bracket (9" extension bolt)

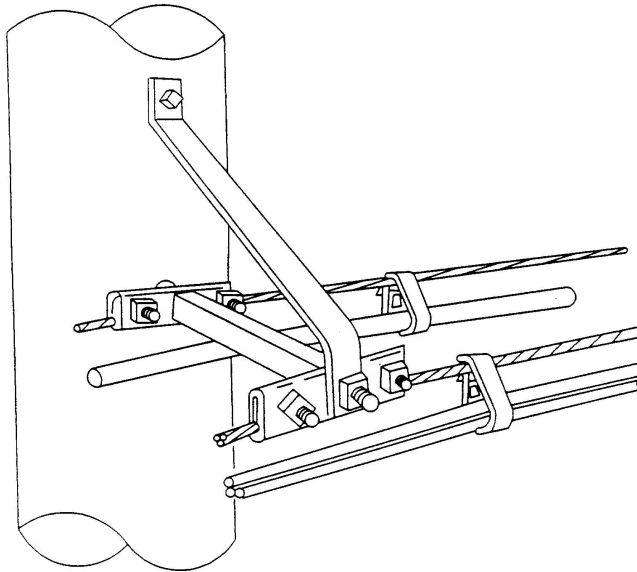

- Fiberglass (Epoxy Rod) Stand-off

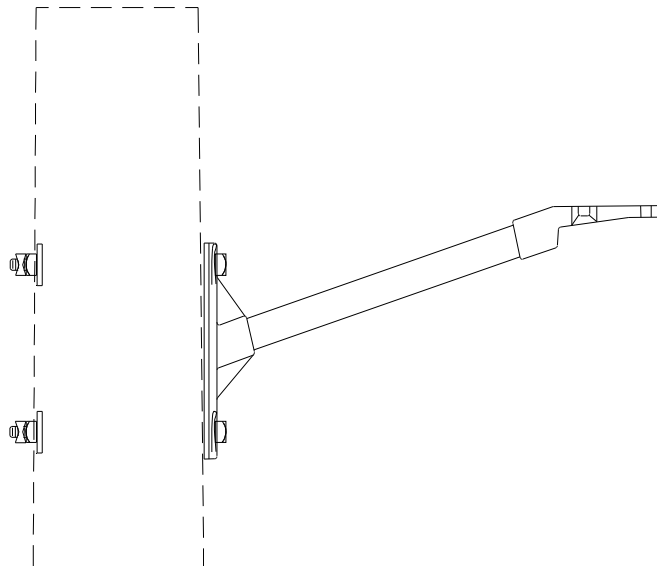

- “E”arm or “F” arm (4 x 4, or 4 x 6 which can support facilities on both ends)

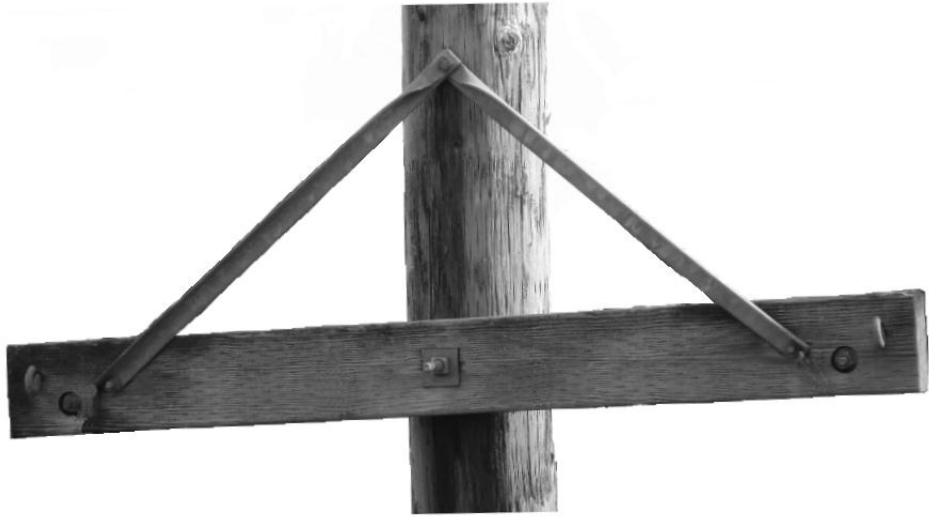

- Power Cross-arm

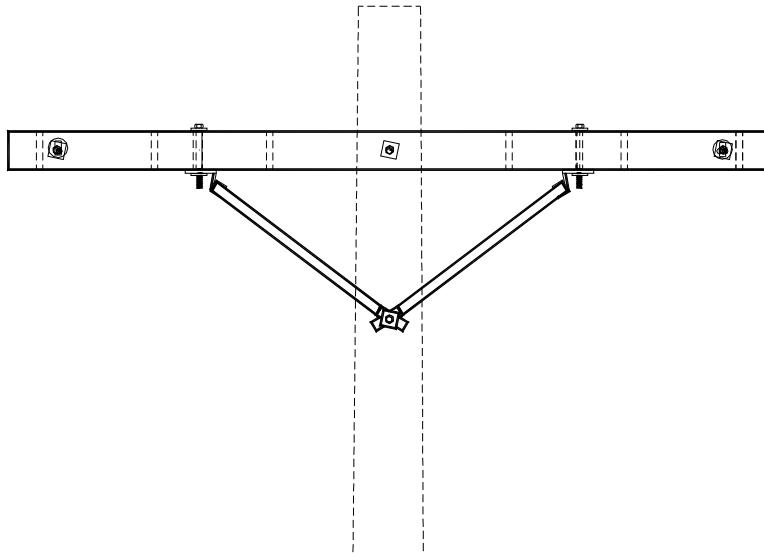

- Braceless Cross-arm (fiberglass)

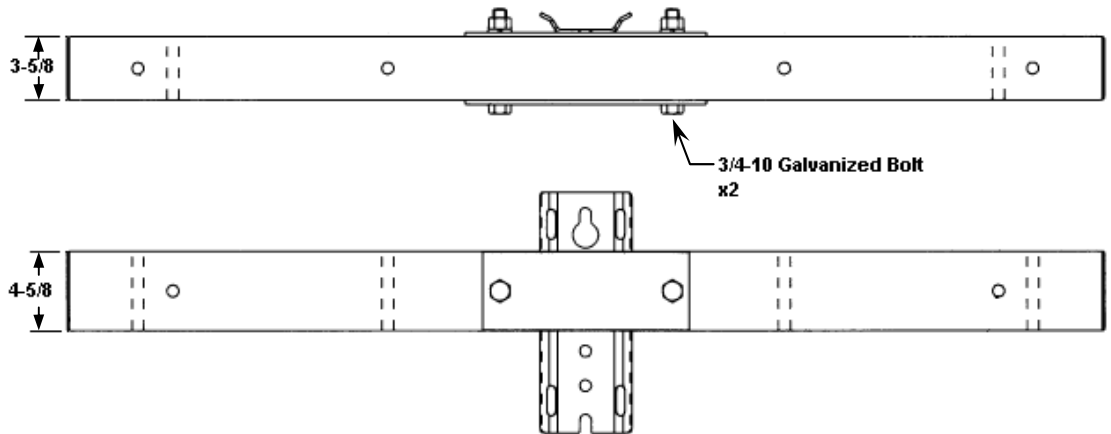

- Wood cross arm / Alley arm (can support facilities on one end)

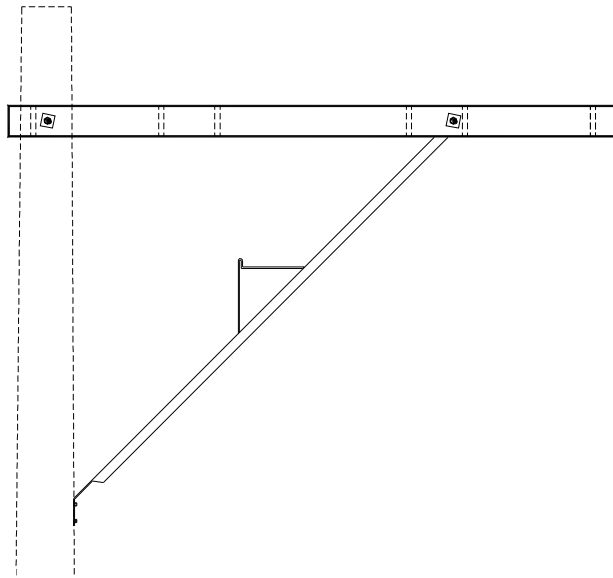

- Double arms

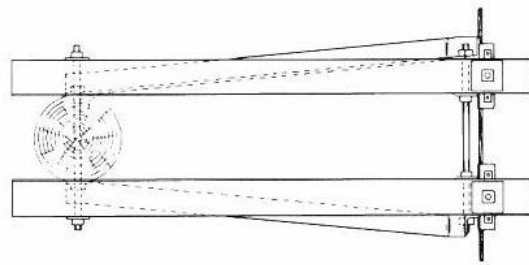
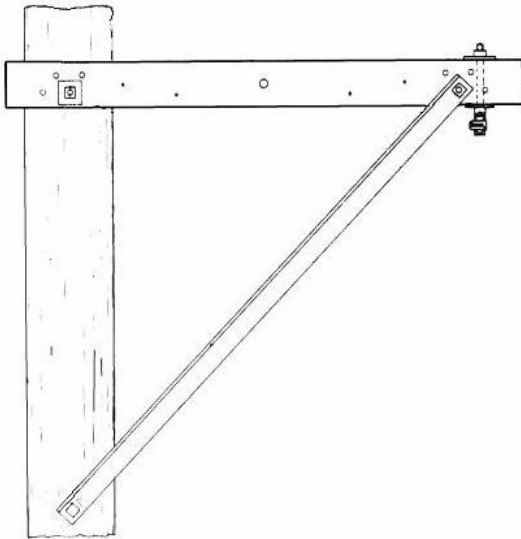

D. BRACES:

- Flat

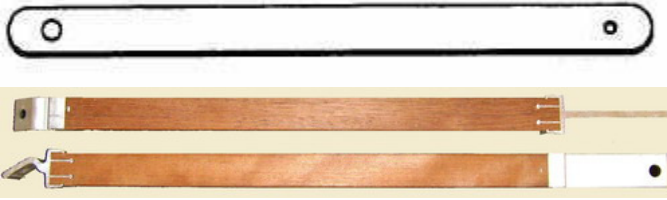

- Curved

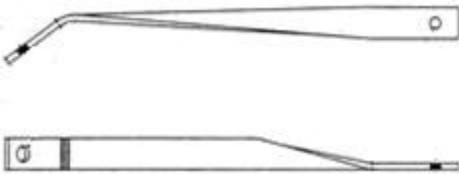

- Angle Iron (w/4" brace)

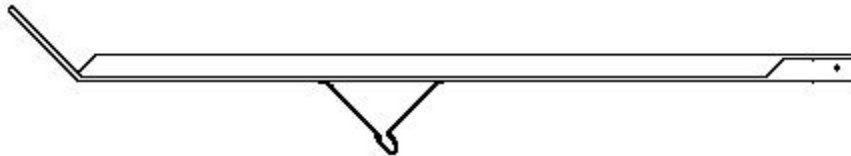

- V Brace

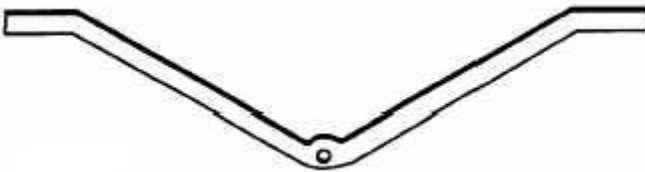

E. LENGTHS OF ARMS:

- Fiberglass (6" increments ranging from 6" to 36")
- Wood arms (6" increments ranging from 3' to 12')
- Metal arm sizes (24" and 48")

F. POLE GAINS: There are two methods to “gain” a pole (create a flat surface on the round wooden pole):

- “Pre-notched” flat surface that is performed by the pole manufacturer
- Pole Gain hardware that is bolted to the pole to create a flat surface to which the wood arm or structure is then attached

(Note: Gains can be “manually” cut into the pole in the field. This is no longer a common practice and should only be performed with the pole owner’s permission)

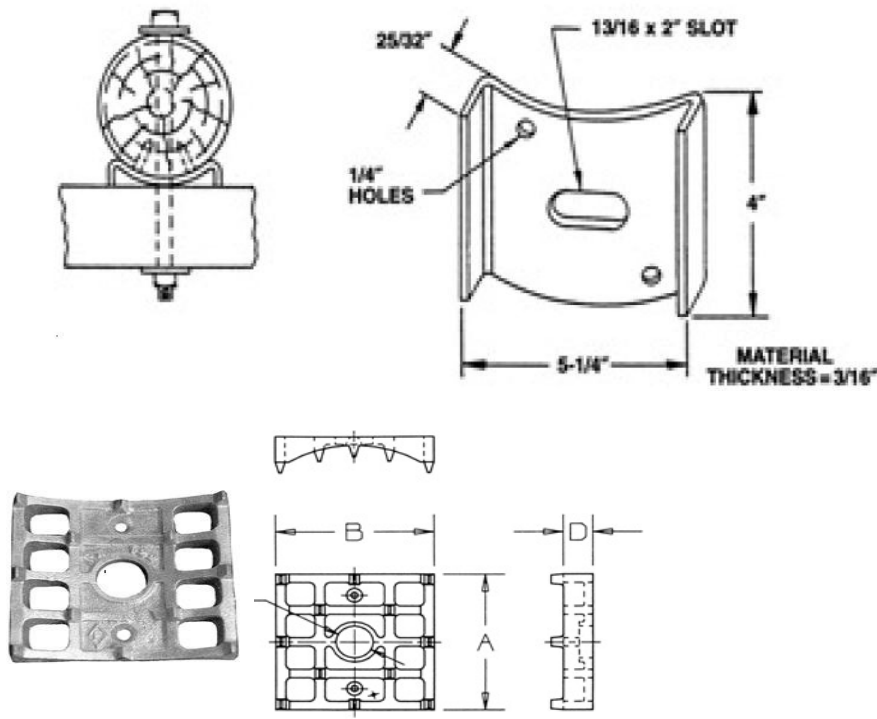

G. INSTALLATION:

- Keep the wood arms perpendicular to the lead whenever possible
- Keep wood arms level
- Use pre-drilled holes whenever possible
- Use the appropriate length of bolt to avoid climbing hazard
- Position based on manufacture’s specifications
- Select appropriate accompanying brace(s)
- Observe climbing space
- Place cross-arms to be centered on the pole
- Treat drilled holes with preservative prior to mounting
- Arms should be placed on the same face of the pole for all utilities if possible

CHAPTER 8 - EQUIPMENT PICTORIAL

This document is intended to provide education on common Construction Practices for aerial construction of power and telecommunications facilities. This is not an official codebook, nor should it be construed as a construction manual. When constructing aerial facilities, please refer to the governing codes, such as the National Electrical Safety Code, National Electric Code, Oregon Public Utility Commission Safety Rules, Oregon Occupational Safety And Health Administration, State, County and Municipal codes, and all other applicable standards, including contracts.

The 2007 National Electrical Safety Code (NESC) addresses equipment in section 38

Table of Contents:



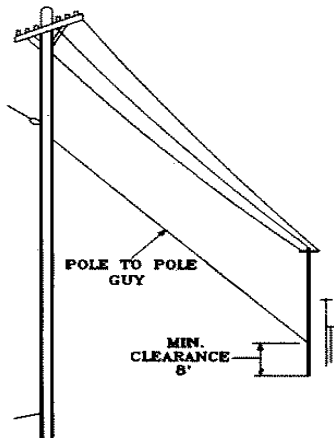
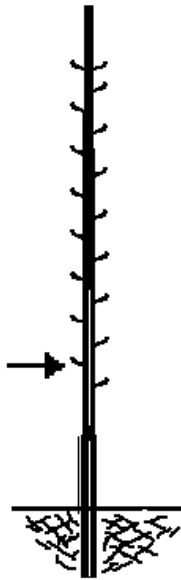
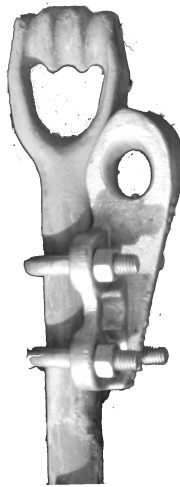

- A. Definition of Equipment
- B. General Equipment
- C. Supply Equipment (Power)
- D. Telco Equipment
- E. Cable Equipment
- F. Fiber Equipment
- G. Wireless Equipment

A. DEFINITION OF EQUIPMENT: Equipment is defined in the NESC as “A general term including fittings, devices, appliances, fixtures, apparatus, and similar terms used as part of or in connection with an electric supply or communications system”. In this section, Equipment is used to define a common language for the different parts of the aerial utilities facilities on poles, structures and towers, and shows the OJUA accepted abbreviations.

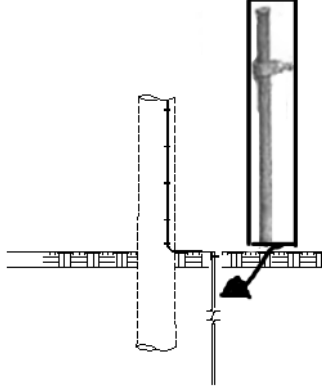
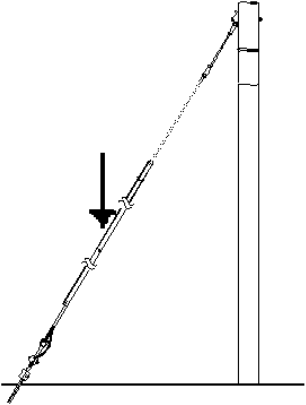
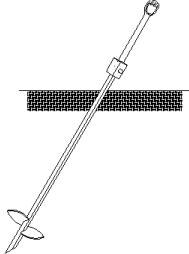
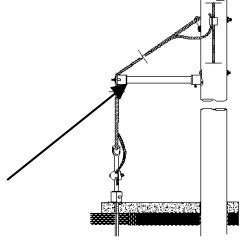
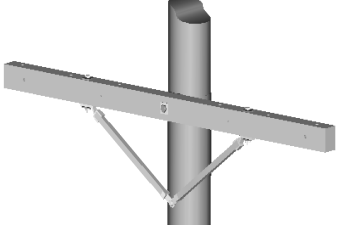

B. GENERAL EQUIPMENT): This equipment is used by all factions of aerial utilities. These types include, but are not limited to:

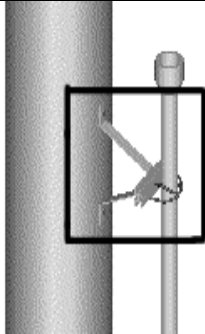
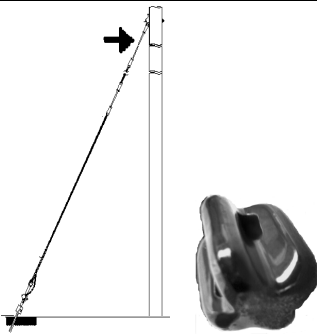
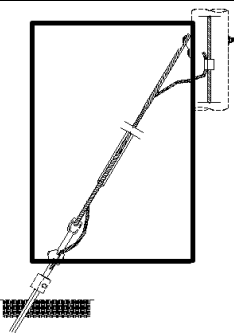
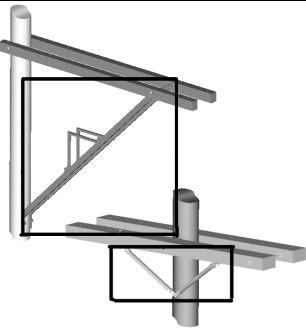
 <p>A Pole to Pole Guy exists on poles where no anchor room is available. The guy attaches at a lower location on the next pole. That pole acts as the anchor for the PPG</p>		
<p>Pole to Pole Guy (PPG)</p>	<p>Pole Step (STEP)</p>	<p>Anchor (auxiliary) (AANC)</p>



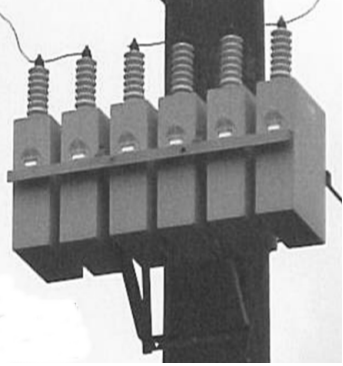
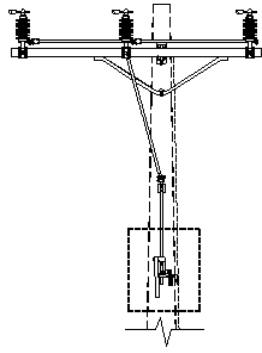

B. General Equipment (cont):

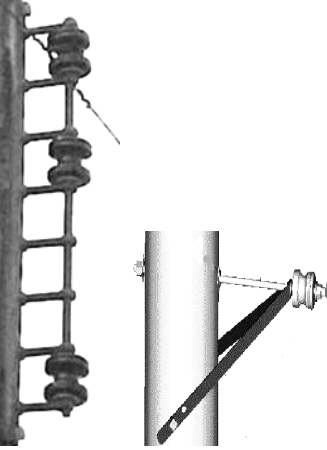
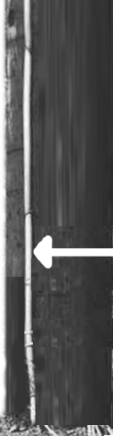
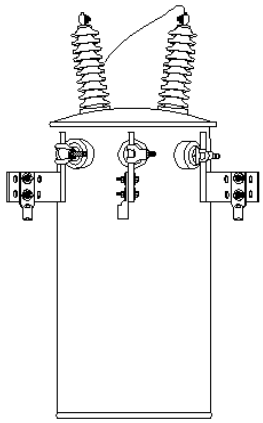
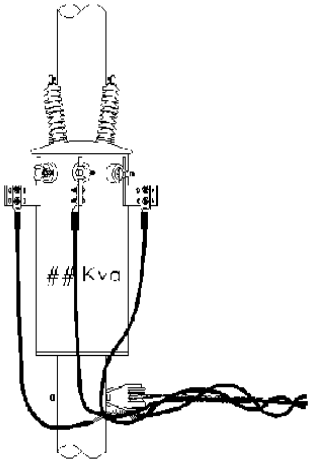
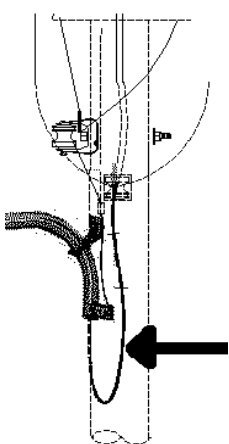
		
<p>Risers (RIS)</p>	<p>Ground rods (GRND)</p>	<p>Guy Markers (GM)</p>
		
<p>Anchor (ANC)</p>	<p>Sidewalk Fixture (SWF)</p>	<p>Crossarm (XARM)</p>
		
<p>Ground Wire (GRWR)</p>	<p>Stand off Bracket (SOB)</p>	<p>Insulator Guy (INS)</p>
		
<p>Down Guy (GUY)</p>	<p>Crossarm Brace (XARB)</p>	<p>Cross-arm (fiberglass)XARF</p>



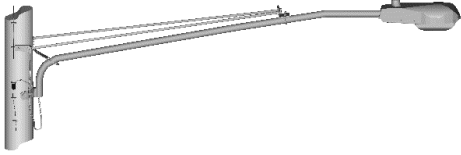
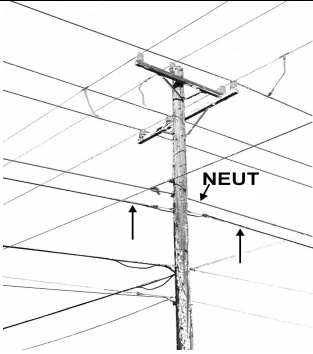
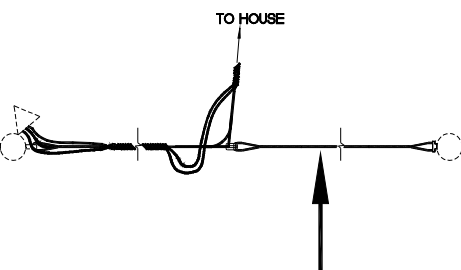
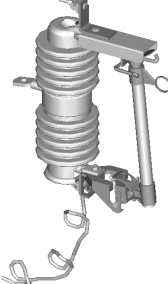

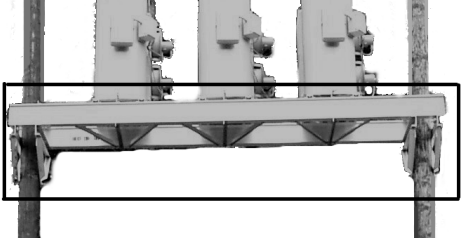
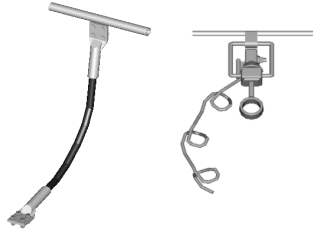
C. SUPPLY EQUIPMENT: All types of Supply Equipment can not be listed here. The examples given represent a general overview.

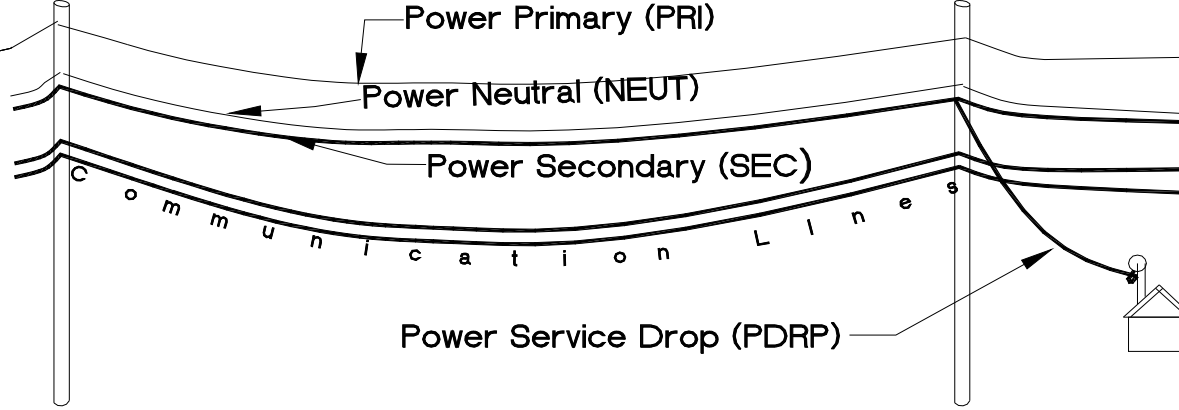
		
<p>Power Capacitor (PCAP)</p>	<p>Power Switch Handle (SWCH)</p>	<p>Power Meter (PMR)</p>
		
<p>Secondary Bracket (PBRK)</p>	<p>U-Guard (UGRD)</p>	<p>Power Transformer (XFMR)</p>
		
<p>Secondary (SEC)</p>	<p>Drip Loop (PDLP)</p>	

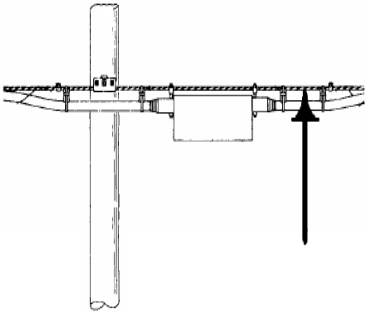

C. Supply Equipment (Cont): All types of Supply Equipment cannot be listed here. The examples given represent a general overview.

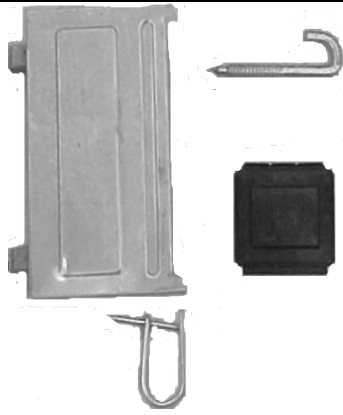
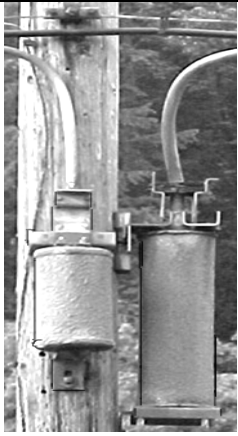
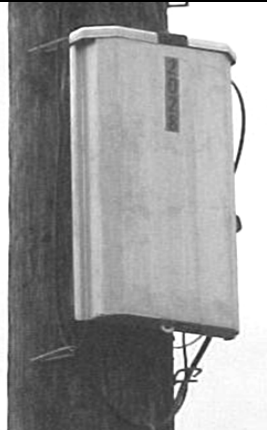
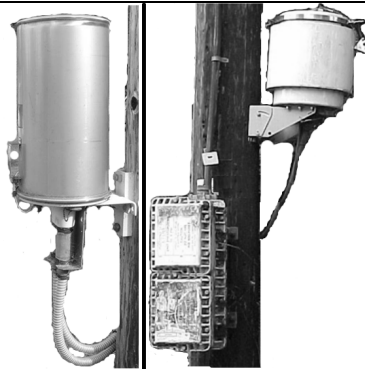
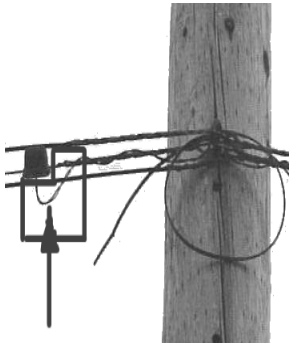
		
<p>Streetlight (SLT)</p>	<p>Supply Fiber (SPFO)</p>	
		
<p>Power Service Support Wire (PSSW)</p>	<p>Power Cutout (PCAP)</p>	<p>Padmount Equipment (PAD)</p>
		
<p>Platform (PF)</p>	<p>Power Jumper(JUMP)</p>	<p>Pedestal (PED)</p>
		

D. TELCO EQUIPMENT: All types of Telco Equipment can not be listed here. The examples given represent a general overview.

		
<p>Communication Mainline (COML)</p>	<p>Communication Cross-Connect (XBOX)</p>	<p>Platform (PF)</p>
		
<p>Communication Equipment (other) (CEO)</p>	<p>Communication Load Coil (LOAD)</p>	<p>Communication Terminal (TRM)</p>
		
<p>Communication Repeater (REP)</p>	<p>Communications Bridle Wire (BRW)</p>	

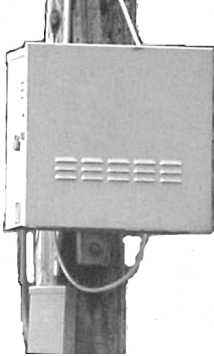
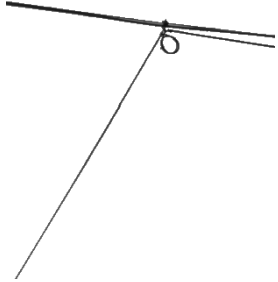
E. CABLE EQUIPMENT: All types of Cable Equipment cannot be listed here. The examples given represent a general overview.

		
<p>Communication Mainline (COML)</p>	<p>Communication Power Supply (PS)</p>	<p>Communication Drop (COMD)</p>
		
<p>Pedestal (PED)</p>	<p>Pedestal (PED)</p>	

F. FIBER EQUIPMENT: All types of Fiber Equipment cannot be listed here. The examples given represent a general overview.

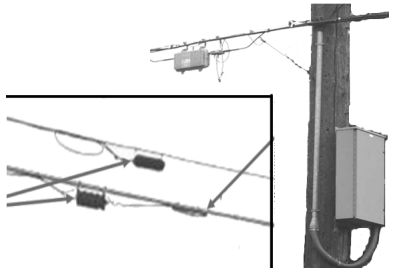
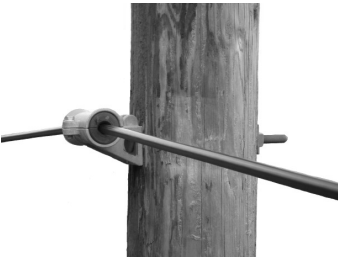
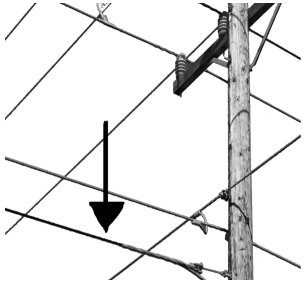
		
<p>Fiber Equipment (other) (FEO)</p>	<p>Communications Fiber-optic (COFO)</p>	<p>Supply Fiber-optic (SPFO)</p>

G. WIRELESS EQUIPMENT: All types of Wireless Equipment cannot be listed here. The examples given represent a general overview.



Antennas (ANT)



Wireless Equipment (WEO)